



SKF Lubrication Products and Systems

The industry's most complete resource for knowledge-engineered lubrication solutions

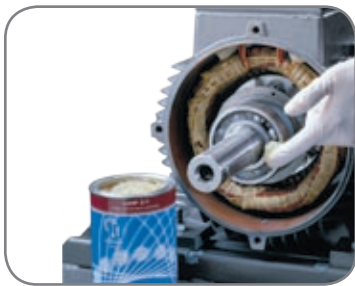

Table of contents



Lubricants

5



Manual lubrication

29



Automatic lubricators

37



Pre-engineered systems

51



Accessories

81

Thousands of lubrication points. One source for lubrication expertise.

With more than 100 years of rotating machinery expertise, SKF knows bearings. And since much of that expertise involves the science of tribology – the study of how friction affects moving parts – SKF knows lubrication, too.

For example, as much as 50% of premature bearing failures are caused by lubrication problems – too much, too little, the wrong type, or contaminated lubricant. Preventing such lubrication-related failures, as well as ensuring optimal bearing performance,

Lubricants



The extensive line of SKF lubricants includes a range of greases and oils, and reflects decades of research and development across many industries. The comprehensive guide featured in this catalog makes choosing the right lubricant easy – select the appropriate grease or oil according to the temperature, speed and load ranges of a particular application.

Manual lubrication



Comprised of grease guns, packers, pumps and meters, SKF manual lubrication products give maintenance professionals many user-friendly tools to keep bearings supplied with precise amounts of contaminant-free grease.

Automatic lubricators



From single-point to multi-point units, SKF automatic lubricators provide reliable time- and labor-saving alternatives to manual lubrication. Around-the-clock SKF solutions such as SYSTEM 24 and SYSTEM MultiPoint provide precise, contaminant-free grease, with minimal risk of over- or under-lubricating.

Pre-engineered systems



The SKF pre-engineered systems offering consists of systems from Vogel, a global leader in centralized lubrication and also part of SKF. These virtually maintenance-free lubrication systems supply lubricant from a central source to the points on a machine at which friction occurs. Bearing wear and tear is reduced with minimal maintenance, and often, some of the friction-generated heat is dissipated with the help of the lubricant.

means delivering the right lubricant, in the right amount, at the right time, to the right lubrication point.

Today, SKF delivers a complete line of lubrication solutions to do exactly that.

With our acquisitions of Vogel Lubrication, Inc. and the lubrication division of Safematic, SKF lubrication products now range from lubricants themselves to state-of-the-art automatic and centralized lubrication systems.



Accessories



SKF lubrication accessories include a broad range of products designed to make lubrication safer, more efficient, and more convenient for operators. Disposable gloves improve worker

safety, while Oil Safe dispensing and storage drums and lids protect against contamination. Small, portable daily lubrication kits and hand-held grease pumps make maintenance tasks easier, while large pumps for centralized and chain lubrication systems deliver measurable savings.

Lubricants

Bearing grease selection basics	6
Bearing grease selection charts	7
Relubrication intervals	10
Lubrication methods	10
SKF bearing greases and their applications	11
Glossary of lubrication terms	16
Chain Oil range	20
Dry Film Lubricant	21
Anti-fretting Agent	22
Anti-corrosive Agent	22
Technical data	23



SKF bearing greases: the perfect solution for every application

Even the very best bearing can only show optimum performance when it is lubricated correctly. Here, it is extremely important to choose the right bearing grease and to apply the most suitable lubrication intervals and methods. This realization has prompted SKF, the world's leading manufacturer of rolling bearings, to look intensively into the subject of lubrication. SKF engineers consider grease to be a "fundamental" component of the bearing arrangement and thus, as important as the bearing, housing and sealing.

SKF's vast experience in the development of rolling bearings forms the basis for the development of a special range of lubricants, the superior quality of which is obtained through continuous testing and studies.

The strict standards and testing parameters developed and applied at the SKF Engineering and Research Center have become internationally recognized benchmarks for bearing greases. The comprehensive range of SKF bearing greases is the result of many decades of research and development. Each individual lubricant is precisely adjusted to the respective field of application.

SKF sets the standard

Tangible performance parameters mean more to SKF than the chemical composition of the lubricant. The chemical composition is not the only factor in determining the quality of a particular grease, since modern lubricants are extremely complex. SKF has set the standards for developing special testing parameters.

Bearing grease selection

Selecting the right bearing grease for a certain application is essential for achieving the maximum service life of a bearing.

Selection criteria for correct lubrication include bearing type and size, temperatures, speeds and loads, as well as the desired service life and relubrication intervals.

To select the proper SKF grease, refer to the reference table for temperature, speed and load ranges. SKF greases suitable for use in an application based on the combination of temperature, speed and load ranges are shown in the charts on pages 7-9. More information about all SKF greases can be found on pages 11 to 15 and in the technical information section on pages 23 to 28.



Bearing grease selection

Generally use if: Speed = M, Temperature = M and Load = M	LGMT 2	General purpose
Unless:		
Expected bearing temperature continuously > 100 °C / 212 °F	LGHP 2	High temperature
Expected bearing temperature continuously > 150 °C / 302 °F, demands for radiation resistance	LGET 2	Extremely high temperature
Low ambient -50 °C / -58 °F, expected bearing temperature < 50 °C / 122 °F	LGLT 2	Low temperature
Shock loads, heavy loads, frequent start-up / shut-down	LGEP 2	High load
Food processing industry	LGFP 2	Food processing
"Green" biodegradable, demands for low toxicity	LGGB 2	"Green" biodegradable

Note: – For areas with relatively high ambient temperatures, use LGMT 3 instead of LGMT 2
 – For special operating conditions, refer to the SKF bearing grease selection chart

Bearing operating parameters

Temperature L = Low M = Medium H = High EH = Extremely high	<50 °C / 122 °F 50 to 100 °C / 122 to 230 °F >100 °C / 212 °F > 150 °C / 302 °F
Speed for ball bearings EH = Extremely High VH = Very High H = High M = Medium L = Low	n.dm over 700 000 n.dm up to 700 000 n.dm up to 500 000 n.dm up to 300 000 n.dm below 100 000
Speed for roller bearings H = High M = Medium L = Low VL = Very Low	SRB/TRB/CARB n.dm over 210 000 n.dm up to 210 000 n.dm up to 75 000 n.dm below 30 000
Speed for roller bearings H = High M = Medium L = Low VL = Very Low	CRB n.dm over 270 000 n.dm up to 270 000 n.dm up to 75 000 n.dm below 30 000
Load VH = Very high H = High M = Medium L = Low	C/P < 2 C/P ~ 4 C/P ~ 8 C/P 15



SKF bearing grease selection chart

Bearing working conditions	Temp	Speed	Load	Vertical shaft	Fast outer ring rotation	Oscillating movements	Severe vibrations	Shock load or frequent start-up	Low noise	Low friction
LGMT 2	M	M	L to M	○	—	—	+	—	—	○
LGMT 3	M	M	L to M	+	○	—	+	—	—	○
LGEP 2	M	L to M	H	○	—	○	+	+	—	—
LGFP 2	M	M	L to M	○	—	—	—	—	—	○
LGEM 2	M	VL	H to VH	○	—	+	+	+	—	—
LGEV 2	M	VL	H to VH	○	—	+	+	+	—	—
LGLT 2	L to M	M to EH	L	○	—	—	—	○	+	+
LGGB 2	L to M	L to M	M to H	○	—	+	+	+	—	○
LGWM 1	L to M	L to M	H	—	—	+	—	+	—	—
LGWA 2	M to H	L to M	L to H	○	○	○	○	+	—	○
LGHB 2	M to H	VL to M	H to VH	○	+	+	+	+	—	—
LGHP 2	M to H	M to H	L to M	+	—	—	+	○	+	○
LGET 2	VH	L to M	H to VH	○	+	+	○	○	—	—

(*1) LTL = Low Temperature Limit

HTPL = High Temperature Performance Limit

(*2) mm²/s at 40 °C / 104 °F = cSt.

(*3) LGGB 2 can withstand peak temperatures of 120 °C / 250 °F

(*4) LGWA 2 can withstand peak temperatures of 220 °C / 428 °F

(*5) LGHB 2 can withstand peak temperatures of 200 °C / 392 °F

Rust inhibiting properties	Description	Temperature range (*1)		Thickener / base oil	Base oil viscosity (*2)
		LTL	HTPL		
+	General purpose industrial and automotive	-30 °C -22 °F	120 °C 250 °F	Lithium soap / mineral oil	110
○	General purpose industrial and automotive	-30 °C -22 °F	120 °C 250 °F	Lithium soap / mineral oil	120
+	Extreme pressure	-20 °C -4 °F	110 °C 230 °F	Lithium soap / mineral oil	200
+	Food compatible	-20 °C -4 °F	110 °C 230 °F	Aluminium complex / medical white oil	130
+	High viscosity plus solid lubricants	-20 °C -4 °F	120 °C 250 °F	Lithium soap / mineral oil	500
+	Extremely high viscosity with solid lubricants	-10 °C -14 °F	120 °C 250 °F	Lithium-calcium soap / mineral oil	1 020
○	Low temperature, extremely high speed	-50 °C -58 °F	110 °C 230 °F	Lithium soap / PAO oil	18
○	Green biodegradable, low toxicity (*3)	-40 °C -40 °F	90 °C 194 °F	Lithium-calcium soap / synthetic ester oil	110
+	Extreme pressure, low temperature	-30 °C -22 °F	110 °C 230 °F	Lithium soap / mineral oil	200
+	Wide temperature, extreme pressure (*4)	-30 °C -22 °F	140 °C 284 °F	Lithium complex soap / mineral oil	185
+	EP high viscosity, high temperature (*5)	-20 °C -4 °F	150 °C 302 °F	Complex calcium sulphonate / mineral oil	400
+	High performance polyurea grease	-40 °C -40 °F	150 °C 302 °F	Di-urea / mineral oil	96
○	Extreme temperature	-40 °C	260 °C	PTFE / synthetic (fluorinated polyether)	400

+ = Recommended

○ = Suitable

— = Not suitable

Relubrication intervals

Choosing the right bearing grease for a certain application is critical to bearing performance. Applying the correct quantity of grease at the right intervals is of equal importance. Over- or under-greasing as well as inadequate lubrication methods can shorten the bearing's service life. For determining the right amount of grease and the correct relubrication intervals for a specific application, SKF has developed DialSet, a simple computerized relubrication calculation program. Calculated relubrication intervals are based on the latest lubrication theories published in the SKF General Catalogue (6000 EN) and depend on bearing type used, application conditions and properties of selected bearing grease.

Lubrication methods

The lubrication method used is equally important to the right bearing grease, quantity and lubrication intervals. Using lubricators, manual or automatic, facilitates proper lubricant supply to the application. Maintaining cleanliness when lubricating bearings is crucial, as contamination can cause the bearing to fail prematurely.

Using a grease meter in combination with a grease gun or pump during manual lubrication helps ensure the supply of the right quantity of grease. SKF's range of grease guns, pumps and lubrication accessories is designed for contamination-free grease supply as well as ease-of-use.

Continuous lubrication, using automatic lubricators or systems, provides the application with a consistent and controlled supply of bearing grease. This reduces the risk of over- or under-greasing and positively contributes to optimizing the bearing's service life. Additionally, automatic relubrication reduces the risk of contamination. Around-the-clock solutions offered by SKF provide precise and reliable grease supply, adjusted to the application's needs.

Grease failure process

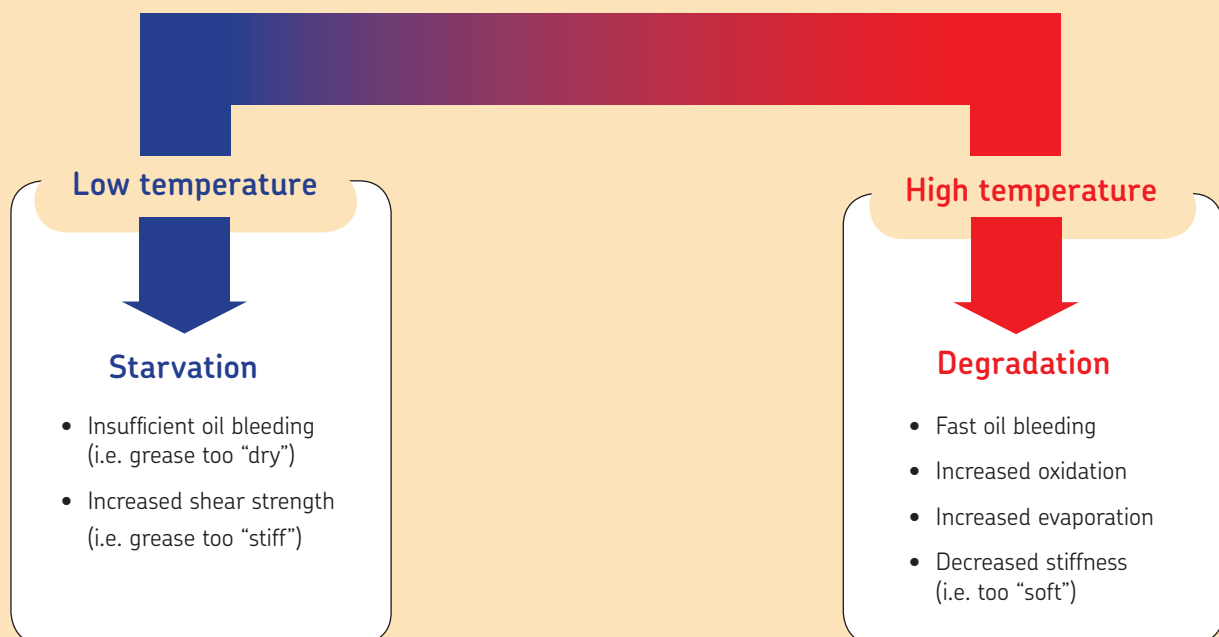

SKF Bearing Greases and their applications

LGMT 2

SKF general purpose industrial and automotive bearing grease

LGMT 2 is mineral oil based lithium soap thickened grease with excellent thermal stability within its operating temperature range. This premium quality, general purposes grease is suitable for a wide range of industrial and automotive applications.

- Excellent oxidation stability
- Good mechanical stability
- Excellent water resistance and rust inhibiting properties

Recommended applications

- Agricultural equipment
- Automotive wheel bearings
- Conveyors
- Small electric motors
- Industrial fans

Other uses

- Severe vibrations
- Rust inhibiting properties

LGMT 3

SKF general purpose industrial and automotive bearing grease

LGMT 3 is mineral oil based lithium soap thickened grease. This premium quality, general purpose grease is suitable for a wide range of industrial and automotive applications.

- Excellent rust inhibiting properties
- High oxidation stability within its recommended temperature range

Recommended applications

- Bearings >100 mm (3.9 in) shaft size
- Outer bearing ring rotation
- Vertical shaft applications
- Continuous high ambient temperatures >35° C (95° F)
- Propeller shafts
- Agricultural equipment
- Car, truck and trailer wheel bearings
- Large electric motors

Other uses

- Vertical shafts
- Severe vibrations

LGEP 2

SKF high load, extreme pressure bearing grease

LGEP 2 is mineral oil based lithium soap thickened grease with extreme pressure additives. This grease provides good lubrication in operating temperatures ranging from -20 °C (-4 °F) up to 110 °C (230 °F)

- Excellent mechanical stability
- Extremely good corrosion inhibiting properties
- Excellent EP performance

Recommended applications

- Pulp and paper making machines
- Jaw crushers
- Dam gates
- Work roll bearings in steel industry
- Heavy machinery, vibrating screens
- Crane wheels, sheaves

Other uses

- Severe vibrations
- Shock load or frequent start-up



LGWA 2

SKF high load, extreme pressure (EP), wide temperature range bearing grease

LGWA 2 is premium quality mineral oil based lithium complex grease with extreme pressure (EP) performance. LGWA 2 has such properties that it can be recommended for a wide range of industrial and automotive applications.

- Excellent lubrication at peak temperatures up to 220° C (428° F) for short periods
- Protection of wheel bearings operating under severe conditions
- Effective lubrication in wet conditions
- Good water and corrosion resistance
- Excellent lubrication under high loads and low speeds

Recommended applications

- Wheel bearings in cars, trailers and trucks
- Washing machines
- Electric motors

Other uses

- Oscillating movements
- Shock load or frequent start-up
- Rust inhibiting properties

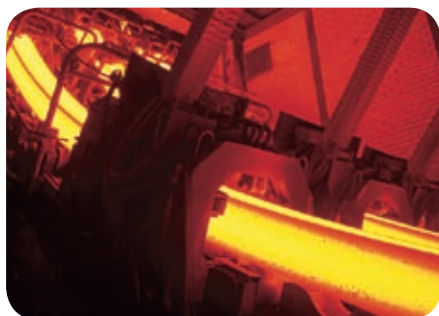

LGHB 2

SKF high load, high temperature, high viscosity bearing grease

LGHB 2 is a premium quality, high viscosity, mineral oil based grease using the latest complex calcium, sulphate soap technology. This grease contains no additives and the extreme pressure characteristics are created within the soap structure.

- Excellent anti-oxidation and anti-corrosion properties
- Good EP performance in applications running at high loads

Recommended applications

- Steel on steel plain bearings
- Pulp and paper making machines
- Asphalt vibrating screens
- Continuous casting machines
- Sealed spherical roller bearings operating up to 150 °C (302 °F)
- Withstands peak temperatures of 200 °C (392 °F)
- Work roll bearings in steel industry
- Mast rollers of fork lift trucks

Other uses

- Fast outer ring rotation
- Oscillating movements
- Severe vibrations
- Shock load or frequent start-up
- Rust inhibiting properties

LGHP 2

SKF high performance, high temperature bearing grease

LGHP 2 is premium quality mineral oil based grease, using a modern Polyurea (di-urea) thickener. It is suitable for ball (and roller) bearings required to run extremely quiet, operating at a wide temperature range from -40 °C (-40 °F) up to 150 °C (302 °F), at medium to high speeds.

- Extremely long life at high temperature
- Wide temperature range
- Excellent corrosion protection
- High thermal stability
- Good low temperature start-up performance
- Compatibility with common Polyurea greases
- Compatibility with lithium complex thickened greases
- Low noise characteristics
- Very good mechanical stability

(continued on following page)



LGHP 2

Recommended applications

- Electric motors: small, medium and large
- Industrial fans, including high speed fans
- Water pumps
- Rolling bearings in textile, paper processing and drying machines
- Applications with high speed ball bearings operating at medium and high temperatures
- Clutch release bearings
- Kiln trucks and rollers
- Vertical shaft applications
- Vibrating applications

Other uses

- Vertical shafts
- Severe vibrations
- Low noise
- Rust inhibiting properties

LG2T 2

SKF high temperature, extreme condition bearing grease

LG2T 2 is premium quality, synthetic fluorinated oil based grease using a PTFE thickener. It has excellent lubrication properties at extremely high temperatures exceeding 200 °C (392 °F) up to 260 °C (500 °F).

- Long life in aggressive environments such as very reactive environments or areas with a presence of high purity gaseous oxygen or hexane
- Excellent oxidation resistance
- Good corrosion resistance
- Excellent water and steam resistance

Recommended applications

- Bakery equipment (ovens)
- Kiln truck wheels
- Load rollers in copying machines
- Wafer baking machines
- Textile dryers
- Film stretching tenders
- Electric motors running at extreme temperatures
- Emergency / hot fans
- Vacuum pumps

Other uses

- Fast outer ring rotation
- Oscillating movements

LGWM 1

SKF extreme pressure (EP) low temperature bearing grease

LGWM 1 is a mineral oil based grease using a lithium soap and containing extreme pressure additives. It is very suitable for the lubrication of bearings operating under both radial and axial loads e.g. transport screws.

- Good oil film formation at low temperatures down to -30 °C (-22 °F)
- Good pumpability at low temperature
- Good corrosion protection
- Good water resistance

Recommended applications

- Windmills
- Screw conveyors
- Centralized lubrication systems
- Spherical roller thrust bearing applications

Other uses

- Oscillating movements
- Shock load or frequent start-up
- Rust inhibiting properties



LGLT 2

SKF low temperature, extremely high speed bearing grease

LGLT 2 is premium quality, fully synthetic oil based grease using lithium soap. Its unique thickener technology and its low viscosity oil (PAO) provide excellent lubrication performance at low temperatures (–50 °C) and extremely high speeds, n.dm values of 1.6×10^6 can be reached.

- Low friction torque
- Low level of power loss
- Quiet running behavior
- Extremely good oxidation stability and resistance to water

Recommended applications

- Textile spinning spindles
- Machine tool spindles
- Instruments and control equipment
- Small electric motors used in medical and dental equipment
- In-line skates
- Printing cylinders
- Robots

Other uses

- Low noise
- Low friction



LGEM 2

SKF high viscosity bearing grease with solid lubricants

LGEM 2 is a premium quality, high viscosity, mineral oil based grease using a lithium soap containing molybdenum disulphide and graphite.

- Good lubrication for bearings operating under high loads and slow rotations
- Safe lubrication due to the inclusion of molybdenum disulphide and graphite

Recommended applications

- Rolling element bearings running at low speed and very high loads
- Jaw crushers
- Track laying machines
- Lift mast wheels
- Building machines such as mechanical rams, crane arms and crane hooks

Other uses

- Oscillating movements
- Severe vibrations
- Shock load or frequent start-up
- Rust inhibiting properties



LGEV 2

SKF extremely high viscosity bearing grease with solid lubricants

LGEV 2 is a premium quality, extremely high viscosity, mineral oil based grease using a lithium–calcium soap containing molybdenum disulphide and graphite.

- Excellent lubrication properties due to the inclusion of molybdenum disulphide and graphite solid
- Very suitable for lubricating large sized spherical roller bearings subject to high loads and slow rotation, a situation where microslip is likely to occur
- Extremely mechanically stable providing good water resistance and corrosion protection

Recommended applications

- Trunnion bearings on rotating drums
- Support and thrust rollers on rotary kilns and dryers
- Bucket wheel excavators
- Slewing ring bearings
- High pressure roller mills
- Crushers

Other uses

- Oscillating movements
- Severe vibrations
- Shock load or frequent start-up
- Rust inhibiting properties

LGGB 2

SKF green biodegradable bearing grease

LGGB 2 is biodegradable, low toxicity, synthetic ester oil based grease using a lithium–calcium thickener. It has excellent lubrication properties for a wide range of applications operating under different conditions.

- Compliance with current regulations on toxicity and biodegradability
- Good performance in applications with steel–on–steel spherical plain bearings, ball bearings and roller bearings
- Good low temperature start–up performance
- Good corrosion inhibiting properties
- Suitable for medium to high loads

Recommended applications

- Agricultural and forestry equipment
- Construction and earthmoving equipment
- Mining and conveying equipment
- Water treatment and irrigation
- Locks, dams, bridges
- Linkages, rod ends
- Other applications where contamination of the environment is a concern

Other uses

- Oscillating movements
- Severe vibrations
- Shock load or frequent start-up

LGFP 2

SKF food compatible bearing grease

LGFP 2 is clean, non-toxic bearing grease, which is based on medical white oil using an aluminium complex soap. This grease is formulated using only FDA* listed ingredients and is authorised by the NSF** for category H1*** service.

- Compliance with all existing legislation on food protection
- High resistance to water washout making it suitable for applications subject to frequent wash down
- Excellent grease life
- Excellent corrosion resistance
- An essentially neutral pH value

Recommended applications

- Bakery equipment
- Food processing equipment
- Multi-pack cassette bearings
- Wrapping machines
- Conveyor bearings
- Bottling machines

Other uses

- Rust inhibiting properties

* FDA – Food and Drug Administration
** NSF – National Sanitation Foundation
*** H1 – Incidental Contact with Food



Glossary of lubrication terms

Thickener or soap

Thickener or soap is the system which holds the oil and/or additives together to enable the lubricating grease to

function. The thickener system is formed from either soaps or non-soaps. The type of thickener gives the grease its typical characteristics.

Soaps are based on lithium, calcium, sodium, barium or aluminium. Non-soaps are based on organic or non-organic solids, bentonite clay, polyurea or silica gel.

Thickener compatibility chart

	Lithium	Calcium	Sodium	Lithium complex	Calcium complex	Sodium complex	Barium complex	Aluminium complex	Clay	Common Polyurea	Calcium sulphonate complex
Lithium	+	○	–	+	–	○	○	–	○	○	+
Calcium	○	+	○	+	–	○	○	–	○	○	+
Sodium	–	○	+	○	○	+	+	–	○	○	–
Lithium complex	+	+	○	+	+	○	○	+	–	–	+
Calcium complex	–	–	○	+	+	○	–	○	○	+	+
Sodium complex	○	○	+	○	○	+	+	–	–	○	○
Barium complex	○	○	+	○	–	+	+	+	○	○	○
Aluminium complex	–	–	–	+	○	–	+	+	–	○	–
Clay	○	○	○	–	○	–	○	–	+	○	–
Common Polyurea	○	○	○	–	+	○	○	○	○	+	+
Calcium sulphonate complex	+	+	–	+	+	○	○	–	–	+	+

+ = Compatible ○ = Test required – = Incompatible

Base oil compatibility chart

	Mineral/PAO	Ester	Polyglycol	Silicone: methyl	Silicone: phenyl	Polyphenyl-ether	PFPE
Mineral oil / PAO	+	+	–	–	+	○	–
Ester	+	+	+	–	+	○	–
Polyglycol	–	+	+	–	–	–	–
Silicone: methyl	–	–	–	+	+	–	–
Silicone: phenyl	+	+	–	+	+	+	–
Polyphenylether	○	○	–	–	+	+	–
PFPE	–	–	–	–	–	–	+

+ = Compatible ○ = Test required – = Incompatible

Note: SKF high performance, high temperature bearing grease LGHP 2 is not a common polyurea type grease. It is a di-urea bearing grease, which has successfully been tested for compatibility with lithium and lithium complex thickened greases i.e. LGHP 2 is compatible with such greases.

Base oil

The base oil is the oil inside the grease, which provides lubrication under operating conditions. Greases are normally based on mineral oils. Synthetic oils can be used for very specific applications such as extremely high or low temperatures. The base oil generally constitutes more than 70% of a grease's composition.

Base oil viscosity

Viscosity is a measure of a fluid's flow characteristics and is usually expressed in terms of the time required for a standard quantity of the fluid, at a given temperature, to flow through a standard orifice. Since viscosity decreases with increasing temperature, the temperature at which it is measured is always stated. The viscosity of base oils is always indicated as a kinematic viscosity abbreviated to cSt, at 40 °C (104 °F) and often also at 100 °C (212 °F).

Additives

Additives are used to provide additional characteristics such as wear and corrosion protection, friction reducing effects and preventing damage under boundary and mixed lubrication conditions.

Grease consistency/penetration

A measure of the stiffness of a grease. The consistency is classified according to a scale developed by the NLGI (National Lubricating Grease Institute). This is based on the degree of penetration achieved by allowing a standard cone to sink into the grease at a temperature of 25° C (77° F) for a period of five seconds. The depth of penetration is measured on a scale of 10⁻¹ mm and the softer greases allow the cone to penetrate further into the grease, hence the higher penetration number. The test method is in accordance with DIN ISO 2137. Refer to chart below

Drop point

The drop point is the temperature at which the grease sample, when heated, will begin to flow through an opening and is measured according to DIN ISO 2176. The drop point does not relate to the allowable operating service temperature of the grease.

Mechanical stability

The consistency of a rolling bearing grease should not alter, or only slightly be altered during the working life of the rolling bearing. Depending on the application, the following tests can be performed to evaluate the mechanical stability of a grease.

Prolonged penetration test

The grease sample is filled into a cup and, using an automatic device (called a grease worker) subjected to 100,000 double strokes. At the end of the test, the penetration of the grease is measured. The difference between the measured penetration at 60 strokes and after 100,000 strokes penetration is reported as the change in 10⁻¹ mm.

Classification of greases by NLGI consistency number

NLGI number	ASTM worked penetration (10 ⁻¹ mm)	Appearance at room temperature
000	445 – 475	very fluid
00	400 – 430	fluid
0	355 – 385	semi-fluid
1	310 – 340	very soft
2	265 – 295	soft
3	220 – 250	medium hard
4	175 – 205	hard
5	130 – 160	very hard
6	85 – 115	extremely hard



Roll stability test

The change in the grease structure (amount of softening or hardening) can be evaluated by filling a cylinder with a pre-specified quantity of grease. A roller is placed inside the cylinder and the complete unit is rotated for 2 hours at room temperature in accordance with ASTM D 1403. SKF modified the standard test procedure to reflect the application conditions under which the grease is used to either 72 or 100 hours at a test temperature of 80° C (176° F) or 100° C (212° F) respectively. At the end of the test period, the cylinder is allowed to cool to room temperature and the penetration of the grease is measured. The difference between the original penetration and the value measured is reported as the change in penetration in 10^{-1} mm.

SKF V2F test

The candidate grease is tested for mechanical stability using the following procedure. The test rig consists of a railway axle box subjected to vibration shocks of 1Hz from a bouncing hammer producing an acceleration force level between 12 – 15 g's. The test is run at two different speeds, 500 and 1,000 rpm. If the grease, which leaks from the housing through the labyrinth seal which is collected in a tray after 72 hours at 500 rpm, weighs less than 50 grams, the test is continued for a further 72 hours at 1,000 rpm. If the total amount of grease leakage after both tests (72 hours at both 500 and 1,000 rpm) does not exceed 150 grams, then a rating of 'M' is given. If the grease only fulfills the first part of the test (72 hours at 500 rpm with a grease leakage of 50 grams or less) but fails the second stage, a rating of 'm' is given. If the grease leakage after 72

hours at 500 rpm is greater than 50 grams, then it is rated as failed.

Corrosion protection

Lubricating greases should protect metal surfaces from corrosive attack in service. The corrosion protection properties of rolling bearing greases are evaluated using the SKF Emcor method, which is standardized under ISO 11007. Under this test method a mixture of lubricating grease and distilled water is present in the bearing. The bearing alternates during a defined test cycle between standstill and rotation at 80 rpm. At the end of the test cycle, the degree of corrosion is evaluated according to a scale between 0 (no corrosion) and 5 (very severe corrosion). A more severe test method is to use salt water to replace the distilled water following the standard test procedure. In addition, the test can also be carried out by continuously allowing water to flow or wash through the bearing arrangement during the test cycle.

This test method is called the SKF Distilled Water Washout Test. The evaluation procedure is exactly the same as that used under the standardized method. However the procedure places greater demands on the corrosion protection properties of the grease.

Copper corrosion

Lubricating greases should protect copper alloys used in bearings from corrosive attack while in service. The copper corrosion protection properties of rolling bearing greases are evaluated using the standardized method DIN 51811. A copper strip is immersed in the grease sample and placed in an oven. The strip is then cleaned and the degradation is observed. The result is rated by a numerical system.

Water resistance

The water resistance of lubricating greases is measured in accordance with DIN 51 807 part 1. A glass strip is coated with the candidate grease, which is placed into a water-filled test tube. The test tube is immersed in a water bath for three hours at a specified test temperature. The change in the grease is evaluated visually and reported as a value between 0 (no change) and 3 (major change) along with the test temperature.

Oil separation

Lubricating greases release oil when stored for long periods of time or when used in bearings as a function of temperature. This phenomenon is necessary to ensure good lubrication. The degree of oil separation will depend upon the thickener, base oil and manufacturing method. A cup is filled with a given quantity of grease (which is weighed before the test) and a 100 gram weight placed on top of the grease. The complete unit is put into an oven at 40° C (104° F) for one week. At the end of the week, the amount of oil which has leaked through the sieve is weighed and reported as a percentage of weight loss. The amount of oil separation is measured in accordance with DIN 51 817.



Lubricating ability

The SKF R2F machine assesses the high temperature performance and lubricating ability of a grease, simulating the conditions under which large size bearings operate in housings. The test method is carried out under two different conditions. Test A is conducted at ambient temperature and Test B is conducted at 120° C (248° F). A pass rating in the unheated test (Test A) means that a grease can be used to lubricate larger rolling bearings at normal operating temperatures and also in low vibrating applications. A pass in the heated test (Test B) at 120° C (248° F) means that the grease is suitable for use in large roller bearings operating at elevated temperatures.

Rolling bearing grease life

The SKF R0F grease test machine determines the grease life and high temperature performance limit of a lubricating grease. Ten deep groove ball bearings are fitted into 5 housings and filled with a given quantity of grease. The test is undertaken at a pre-determined speed and temperature. Both an axial and radial load is applied and the bearings run until failure. The time to failure is recorded in hours and a Weibull life calculation is made at the end of the test period to establish the grease life. This information can be used to determine relubrication intervals in an application.

EP performances

The 4-ball weld load test

This method evaluates the EP (Extreme Pressure) performance of a lubricating grease. This test method is standardized under DIN 51 350/4. Three steel balls are held in a cup and a fourth ball is rotated against the three balls at a given speed. A starting load is applied and increased at predetermined intervals until the rotating ball seizes and welds to the three stationary balls. The test indicates the point at which the extreme pressure limit of the grease is exceeded. Greases can be considered as EP greases when the weld load is higher than 2,600 N.

The 4-ball wear scar test

This test is performed with the same rig used in the 4-ball weld load test. 1,400 N are applied on the fourth ball for one minute. Then the wear on the three balls is measured. A standard test uses a load of 400 N. However, SKF has decided to increase that to 1,400 N in order to make the test relevant for bearing applications.

False brinelling

Anti-fretting properties of a grease can be relevant for certain applications. SKF can assess these properties using the FAFNIR test standardized as ASTM D4170. Two ball thrust bearings are loaded and oscillated. The wear on each bearing is then measured. Greases offer good fretting protection when the measured wear is below 7 mg.

Chain Oil range

Extending chain life

SKF Chain Oils come in three convenient sizes to suit the needs of most chain applications in industrial environments. The chain oils, medium temperature, high temperature, and food compatible (NSF H1), are available in 5 liter (1.32 gallon) cans, and as an oil fill for the SKF SYSTEM 24 single point automatic lubricator.

Ordering details

Designation	Description
LHFP 150/5 LAGD 125/HFP15*	5 liter (1.32 gallon) can 125 ml (4.25 fl. oz.) SYSTEM 24 unit filled with food processing oil (viscosity ISO 150)
LHHT 265/5 LAGD 125/HHT26*	5 liter (1.32 gallon) can 125 ml (4.25 fl. oz.) SYSTEM 24 unit filled with synthetic high temperature chain oil (viscosity ISO 265)
LHMT 68/5 LAGD 125/HMT68*	5 liter (1.32 gallon) can 125 ml (4.25 fl. oz.) SYSTEM 24 unit filled with mineral EP type chain oil (viscosity ISO 68)
LAGD 60/HMT68*	60 ml (2.03 fl. oz.) SYSTEM 24 unit filled with mineral EP type chain oil (viscosity ISO 68)

* Includes non-return valve

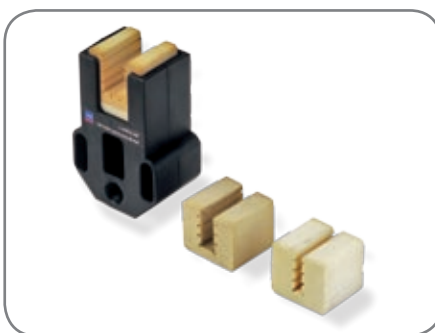

Dry Film Lubricant

LDTs 1

SKF Dry Film Lubricant LDTs 1 is specially developed for automatic lubrication of flat top chains conveyors in the beverage processing industry. It adheres very well on all treated surfaces and has outstanding properties.

The lubricant consists of synthetic oil and is doped with PTFE as solid lubricant. LDTs 1 is NSF* H1** certified for use where incidental contact with food cannot be excluded.

- NSF H1 certified
- Recommended for conveyors using plastic chains
- Excellent lubricating properties



Recommended applications:

- Conveyors in bottling lines
- Applications for the following packaging types:
 - Carton packs
 - Cans
 - PET bottles

* NSF – National Sanitation Foundation

** H1 – Incidental Contact with Food



LDTs 1

	Values	Units
Composition	Mineral oils, hydrocarbons, additives, PTFE	–
Viscosity at 40° C (104° F)	ca 11	mm ² /s
Color	White	–
Temperature range	-5° to +60° C (+23° to +140° F)	° C
Pour point	< 0	° C
Density: 20° C (68° F)	ca 843	kg/m ³
Flash point of the preparation	ca 100	° C
Flash point after evaporation of the solvent	> 170	° C
NSF registration	H1 (registration no: 139739)	

Ordering details

	Units
LDTs 1 / 5	5L can

Product packaged in 5 liter cans; 4 cans per case

Anti-fretting Agent LGAF 3E

SKF LGAF 3E is a greasy, smooth paste especially developed to prevent fretting corrosion between metal surfaces in loose fit arrangements. Fretting corrosion is caused by very slight oscillations or by vibrations, which may lead to serious damage in bearings and other machine parts and can make dismantling almost impossible.

- Reduction of fretting corrosion providing easier dismantling of bearings
- Better sliding on designed loose bearing arrangements such as vibrating screens, truck and car wheel bearings
- Easier removal of general industrial components in a wide range of applications such as nuts, bolts, flanges, studs, bearings, guide pins, couplings, jack screws, lathe centers, push rods, and spline shafts



Anti-corrosive Agent LHRP 1

SKF LHRP 1 provides excellent long-term corrosion protection to ferrous and non-ferrous metals. When applied, it leaves a stable rust protection film over the metal component.

- Excellent rust protection in high humidity environments (tests at 30° C / 80° F – 90% relative humidity indicates full protection for at least one year)
- Excellent long-term indoor storage protection



Technical data

Chemicals and oils LHRP 1 (page 22) LGAF 3E (page 22) LHMT 68, LHHT 265, LHFP 150 (page 20)					
	LHRP 1	LGAF 3E	LHMT 68	LHHT 265	LHFP 150
Description	Anti-corrosive agent	Anti-fretting paste	Medium temperature oil	High temperature oil	Food compatible, NSF H1 oil
Specific gravity	0.815	1.19	0.85	0.91	0.85
Color	Hazy brown	White-beige	Yellow-brown	Yellow-orange	Colorless
Base oil type	Mineral	Mineral and synthetic	Mineral	Synthetic ester	Synthetic ester
Thickener	Not applicable	Lithium soap	Not applicable	Not applicable	Not applicable
Operating temperature range, °C (°F)	– –	–25 to 250° C (–13 to 482° F)	–15 to 90° C (5 to 194° F)	Up to 250° C (482° F)	–30 to 120° C (–22 to 248° F)
Base oil viscosity: 20° C, mm ² /s 40° C, mm ² /s 100° C, mm ² /s	not valid because of thixotropic nature	– 17.5 –	– ISO VG 68 approx. 9	– approx. 265 approx. 30	– ISO VG 150 approx. 19
Flash point	39° C (102° F)	–	200° C (392° F)	approx. 260° C (500° F)	> 200° C (392° F)
Pour point	–20° C (–4° F)	–	–15° C (5° F)	– –	< –30° C (–22° F)
NSF approval	Not applicable	Not applicable	Not applicable	Not applicable	H1 (No: 136858)
Available pack sizes	5 liter can 180 liter drum –	– 0.5 kg can –	125 ml automatic lubricator SYSTEM 24 5 liter can	125 ml automatic lubricator SYSTEM 24 5 liter can	125 ml automatic lubricator SYSTEM 24 5 liter can
Designation	LHRP 1 / (pack size)	LAGF 3E / 0.5	LAGD 125 / HMT68 LHMT 68 / (pack size)	LAGD 125 / HHT26 LHHT 265 / (pack size)	LAGD 125 / HFP15 LHFP 150 / (pack size)

Bearing greases (pages 11 - 15)	LGMT 2	LGMT 3	LGEP 2
DIN 51825 code	K2K-30	K3K-30	KP2G-20
NLGI consistency class	2	3	2
Soap type / thickener	Lithium	Lithium	Lithium
Color	Red brown	Amber	Light brown
Base oil type	Mineral	Mineral	Mineral
Operating temperature range	-30 to 120 °C (-22 to 250 °F)	-30° to 120° C (-22° to 250° F)	-20 to 110 °C (-4 to 230 °F)
Dropping point DIN ISO 2176	>180 °C (>356 °F)	>180 °C (>356 °F)	>180 °C (>356 °F)
Base oil viscosity: 40° C, mm ² /s 100° C, mm ² /s	110 11	120 - 130 12	200 16
Penetration DIN ISO 2137: 60 strokes, 10 ⁻¹ mm 100 000 strokes, 10 ⁻¹ mm	265 - 295 +50 max. (325 max.)	220 - 250 280 max.	265 - 295 +50 max. (325 max.)
Mechanical stability: Roll stability, 50 hrs at 80° C, 10 ⁻¹ mm SKF V2F test	+50 max. 'M'	295 max. 'M'	+50 max. 'M'
Corrosion protection: SKF Emcor: - standard ISO 11007 - water washout test - salt water test (100% seawater)	0 - 0 0 - 0 0 - 1*	0 - 0 0 - 0 -	0 - 0 0 - 0 1 - 1*
Water resistance DIN 51 807/1, 3 hrs at 90° C	1 max.	2 max.	1 max.
Oil separation DIN 51 817, 7 days at 40° C, static, %	1 - 6	1 - 3	2 - 5
Lubrication ability SKF R2F, running test B at 120° C	Pass	Pass	Pass
Copper corrosion DIN 51 811, 110° C	2 max. (130 °C / 266 °F)	2 max.	2 max (100° C)
Rolling bearing grease life SKF ROF test L50 life at 10,000 rpm, hrs		1 000 min. at 130° C (266° F)	
EP performance Wear scar DIN 51350/5, 1,400 N, mm 4-ball test, welding load DIN 51350/4		- -	1,4 max. 2 800 min.
Fretting corrosion ASTM D4170 (mg)		-	5,7*
Available pack sizes	35, 200 g tube 420 ml cart. 1, 5, 18, 50, 180 kg -	- 420 ml cart. 1, 5, 18, 50, 180 kg -	420 ml cart. 1, 5, 18, 50, 180 kg -
Designation	LGMT 2 / (pack size)	LGMT 3 / (pack size)	LGEP 2 / (packsize)

* Typical value

Bearing greases (pages 11 - 15)	LGFP 2	LGLT 2	LGHP 2
DIN 51825 code	K2G-20	KP2G-50	K2N-40
NLGI consistency class	2	2	2-3
Soap type / thickener	Aluminium complex	Lithium complex	Di-urea
Color	Transparent	Beige	Blue
Base oil type	Medical white oil	PAO	Mineral
Operating temperature range	-20° to 110° C (-4° to 230° F)	-50° to 110° C (-58° to 230° F)	-40° to 150° C (-40° to 300° F)
Dropping point DIN ISO 2176	>250° C (>482° F)	>180° C (>356° F)	>240° C (>464° F)
Base oil viscosity: 40° C, mm ² /s 100° C, mm ² /s	130 7,3	18 4,5	96 10,5
Penetration DIN ISO 2137: 60 strokes, 10 ⁻¹ mm 100 000 strokes, 10 ⁻¹ mm	265 - 295 +30 max.	265 - 295 +50 max.	245 - 275 365 max.
Mechanical stability: Roll stability, 50 hrs at 80° C, 10 ⁻¹ mm SKF V2F test		+380 max.	365 max. -
Corrosion protection: SKF Emcor: - standard ISO 11007 - water washout test - salt water test (100% seawater)	0 - 0	0 - 1	0 - 0 0 - 0 0 - 0
Water resistance DIN 51 807/1, 3 hrs at 90° C	1 max.	1 max.	1 max..
Oil separation DIN 51 817, 7 days at 40° C, static, %	1 - 5	< 4	1 - 5
Lubrication ability SKF R2F, running test B at 120° C			Pass
Copper corrosion DIN 51 811, 110° C		1 max. (150° C / 300° F)	1 max.
Rolling bearing grease life SKF ROF test L50 life at 10,000 rpm, hrs	1 000 min. at 110° C (230° F)	> 1 000, 20 000 rpm	1 000 min. at 150° C (302° F)
EP performance Wear scar DIN 51350/5, 1,400 N, mm 4-ball test, welding load DIN 51350/4	1 100 min.	2 000 min	- -
Fretting corrosion ASTM D4170 (mg)		-	7 *
Available pack sizes	- 420 ml cart. 1, 18, 180 kg SYSTEM 24 (LAGD / LAGE)	200 g tube - 1, 25, 180 kg -	- 420 ml cart. 1, 5, 18, 50, 180 kg SYSTEM 24
Designation	LGFP 2 / (pack size)	LGLT 2 / (pack size)	LGHP 2 / (pack size)

* Typical value

Bearing greases (pages 11 - 15)	LGGB 2	LGWA 2	LGHB 2	LGEB 2
DIN 51825 code	KPE 2K-40	KP2N-30	KP2N-20	KFK2U-40
NLGI consistency class	2	2	2	2
Soap type /thickener	Lithium / calcium	Lithium complex sulphonate	Complex calcium	PTFE
Color	Off white	Amber	Brown	Whitish cream
Base oil type	Synthetic ester	Mineral	Mineral	Synthetic (fluorinated polyether)
Operating temperature range, °C (°F)	-40 to 120 (-40 to 250)	-30 to 140 (-22 to 284)	-20 to 150 (-4 to 300)	-40 to 260 (-40 to 500)
Dropping point DIN ISO 2176, °C (°F)	>170 (>338)	> 250 (482)	>220 (>428)	> 300 (572)
Base oil viscosity: 40° C, mm ² /s 100° C, mm ² /s	110 13	185 15	400 – 450 26,5	400 38
Penetration DIN ISO 2137: 60 strokes, 10 ⁻¹ mm 100 000 strokes, 10 ⁻¹ mm	265 – 295 +50 max. (325 max.)	265 – 295 +50 max. (325 max.)	265 – 295 -20 – +50 (325 max.)	265 – 295
Mechanical stability: Roll stability, 50 hrs at 80° C, 10 ⁻¹ mm Roll stability, 72 hrs at 100° C, 10 ⁻¹ mm SKF V2F test	+70 max. (350 max.)	+50 max. change	-20 – +50 change 'M'	± 30 max. (130° C/266° F)
Corrosion protection: SKF Emcor – standard ISO 11007 – water washout test – salt water test (100% seawater)	0 – 0	0 – 0 0 – 0	0 – 0 0 – 0 0 – 0*	1 – 1
Water resistance DIN 51 807 / 1.3 hrs at 90° C	0 max.	1 max.	1 max.	0 max.
Oil separation DIN 51 817, 7 days at 40° C, static, %	0,8 – 3	1 – 5	1 – 3 (at 60° C)	13 max. (30 hrs at 200° C)
Lubrication ability SKF R2F, running test B	Pass at 100° C* (212° F)	Pass at 100° C (212° F)	Pass at 140° C (284° F)	
Copper corrosion DIN 51 811, 100° C	–	2 max. (150° C/300° F)	2 max. (150° C/300° F)	1
Rolling bearing grease life SKF ROF test L50 life at 10,000 rpm, hrs	> 300 at 120° C (250° F)	–	> 1000 at 130° C (266° F)	> 700, 5 600 rpm* at 220° C (428° F)
EP performance Wear scar DIN 51350/5, 1,400 N, mm 4–ball test, welding load DIN 51350/4	1,8 max. 2 600 min.	1,6 max. 2 600 min.	0,86* 4 800 N*	8 000 min.
Fretting corrosion ASTM D4170 (mg)			0 *	
Available pack sizes	– 420 ml cart. 5, 18, 180 kg SYSTEM 24	35, 200 g tube 420 ml cart. 1, 5, 50, 180 kg SYSTEM 24	– 420 ml cart. 5, 18, 50, 180 kg SYSTEM 24	50 g (25 ml) syringe 1 kg
Designation	LGGB 2/ (pack size)	LGWA 2/ (pack size)	LGHB 2/ (pack size)	LGEB 2/ (pack size)

* Typical value

Bearing greases (pages 11 - 15)	LGEM 2	LGEV 2	LGWM 1
DIN 51825 code	KPF2K-20	KPF2K-10	KP1G-30
NLGI consistency class	2	2	1
Soap type /thickener	Lithium	Lithium / calcium	Lithium
Color	Black	Black	Brown
Base oil type	Mineral	Mineral	Mineral
Operating temperature range, °C (°F)	-20 to 120 (-4 to 250)	-10 to 120 (14 to 250)	-30 to 110 (-22 to 230)
Dropping point DIN ISO 2176, °C (°F)	>180 (356)	>180 (356)	>170 (338)
Base oil viscosity: 40° C, mm ² /s 100° C, mm ² /s	500 32	1020 58	200 16
Penetration DIN ISO 2137: 60 strokes, 10 ⁻¹ mm 100 000 strokes, 10 ⁻¹ mm	265 – 295 325 max.	265 – 295 325 max.	310 – 340 +50 max.
Mechanical stability: Roll stability, 50 hrs at 80° C, 10 ⁻¹ mm	345 max.		
Roll stability, 72 hrs at 100° C, 10 ⁻¹ mm		+50 max.	
SKF V2F test	'M'	'M'	
Corrosion protection: SKF Emcor – standard ISO 11007 – water washout test – salt water test (100% seawater)	0 – 0	0 – 0 0 – 0* 0 – 0*	0 – 0 0 – 0
Water resistance DIN 51 807 / 1.3 hrs at 90° C	1 max.	1 max.	1 max.
Oil separation DIN 51 817, 7 days at 40° C, static, %	1 – 5	1 – 5	8 – 13
Lubrication ability SKF R2F, running test B	Pass at 100° C (212° F)		
Copper corrosion DIN 51 811, 100° C	2 max. (90° C/194° F)	1 max.	2 max.
Rolling bearing grease life SKF ROF test L50 life at 10,000 rpm, hrs			
EP performance Wear scar DIN 51350/5, 1,400 N, mm 4–ball test, welding load DIN 51350/4	1,4 max. 3 000 min.	1,2 max. 3 000 min.	1,8 max. 3 200 min.*
Fretting corrosion ASTM D4170 (mg)			5.5 *
Available pack sizes	– 420 ml cart. 5, 18, 180 kg SYSTEM 24	35 g tube 420 ml cart. 5, 18, 50, 180 kg	– 420 ml cart. 5, 50, 180 kg
Designation	LGEM 2/ (pack size)	LGEV 2/ (pack size)	LGWM 1/ (pack size)

* Typical value

Manual lubrication

Grease Packer LAGP 400	30
Bearing Packer VKN 550	30
Grease Guns 1077600 and LAGH 400	31
Battery-driven Grease Gun LAGG 400B	32
Piston Pump with Block Feeder PF-VPBM	33
Grease Meter LAGM 1000E	34
Technical data	35



Grease Packer LAGP 400

To lubricate open bearings

The grease packer LAGP 400 is a low-pressure alternative for emptying SKF grease cartridges. It provides an easy and clean alternative to manual grease packing of open bearings.

- Supplied with three spout caps
- Applies grease to open bearings or open gears



Bearing Packer VKN 550

Contamination-free grease filling

The SKF Bearing Packer, VKN 550, is a sturdy, easy-to-use, efficient and effective bearing grease packer. It can also be used in combination with a standard grease gun, air-operated grease pump or grease filler pump. Although specially designed for taper roller bearings, the SKF bearing packer works for any type of open bearing which needs to be 100% pre-filled with grease.

- Flushes the grease between the rolling elements where it matters most, prolonging the bearing service life
- Closed system and the cover lid prevent ingress of dirt, virtually eliminating contamination
- Allows the operator to pre-fill bearings with grease in a quick and clean way
- Prevents unnecessary grease loss
- Economical and environmentally friendly



Grease Gun 1077600

Easy grease filling

The SKF grease gun is ideal for the agricultural, industrial and construction industries and for private use. The SKF grease gun is delivered with a 175 mm (6.9 in) long extension pipe with hydraulic gripping nozzle. A flexible 500 mm (19.7 in) long pressure hose with hydraulic gripping nozzle is available as an accessory.



- For use with cartridges and loose grease
- Rigid hinging system offers long-lasting use
- Knurled body for firm and safe grip
- High quality steel is dent-resistant for easy cartridge loading
- Special piston design for smooth emptying of cartridges
- 40 MPa (5 800 psi) maximum pressure
- 1.5 cm³ (0.092 in³) volume/stroke
- Also available with a 300 mm (12 in) high pressure hose with a hydraulic gripping nozzle, 1077600H
- A complete set, including 3 extension pipes, high pressure hose, and a carrying case



Ordering details

Designation	Description
1077600	Grease gun with extension pipe
1077600H	Grease gun with flexible hose
1077601	Flexible hose
1077600/SET	Grease gun set

One-hand Operated Grease Gun LAGH 400

Easy grease filling with one hand

Suitable for grease filler pumps and grease cartridges. Ergonomic design, flexible hose and ability to mount the hose vertically and horizontally, make it easy to use.

- Easy-to-use: only one hand is needed to operate the gun
- Refillable: grease-filling nipple and de-airing valve allow filling up by filler or grease pump
- Heavy duty: operating pressure up to 30 MPa
- 0.8 cm³ (0.05 in³) volume/stroke
- Flexible hydraulic type hose: can be bent, can be mounted both horizontally and vertically on the gun



Battery-driven Grease Gun LAGG 400B

Quick and easy grease filling

The Battery-driven grease gun LAGG 400B is a high quality grease gun suitable for lubricating bearings, machines, vehicles and other applications. Ergonomically designed and user-friendly, the grease gun can be used with standard SKF grease cartridges (420 ml) or filled with approximately 500 cm³ (17 fl. oz.) of loose grease.

- Compared to hand operated grease guns, a 420 ml cartridge can be emptied in approximately 10 minutes with minimum effort, resulting in significant cost and time savings
- Electrical operation and the ergonomic design of the hand grip helps reduce operator fatigue compared to manual methods
- Easy-to-use one hand operation makes the grease gun user-friendly
- Supplied with various electrical plugs and two power supply versions (230 and 110 V charger) makes it operational worldwide
- Battery operation allows use in almost all environments without use of a main electrical supply
- Long battery life (1,000 charging cycles) helps reduce product life costs
- Refillable: grease filling nipple and de-airing valve allow filling up by filler or grease pump
- Safety valve setting set to 40 MPa (5,800 psi) helps increase operator safety
- Supplied with M10x1 nozzle, interchangeable with SKF hoses, SKF grease meter LAGM 1000E and other accessories



Replacement parts

Designation

LAGG 400B-1
LAGG 400B-2

Description

High pressure hose 750 mm (29.5 in.) with gripping nozzle
Battery pack

Piston Pump with Block Feeder PF-VPBM

Manually operated

The piston pumps with a block feeder are used on farm machinery, small stackers and construction machinery as well as motor vehicle superstructures.

The piston pump has 6 to 12 lubricant outlets depending on the block feeder. Every stroke of the lever delivers 2 cm³ of lubricant to the feeder.

Also available without block feeder with only one M10 x 1 outlet on the front (order no. VGBL 169-000-146).

The level of the lubricant in the cartridge can be checked by pulling out the cartridge until distinct resistance is felt. When the cartridge is full, the piston rod can be pulled out approximately 415 mm.



Pay attention to cleanliness when changing cartridges, and proceed as follows:

1. Open the toggle-type fastener
2. Unscrew the gun tube
3. Pull piston rod out to the stop
4. Change the cartridge
5. Screw in the gun tube
6. Close the toggle-type fastener
7. Loosen the lock, push in the piston rod up to the stop
8. Actuate the vent valve until grease emerges

Ordering details

Complete unit	Number of outlets
VGBL PF-VPBM-3-2	6
VGBL PF-VPBM-4-2	8
VGBL PF-VPBM-5-2	10
VGBL PF-VPBM-6-2	12
VGBL 169-000-146	1 (Gun only)

See Accessories chapter for tubing, fittings and connectors.
See Lubricants chapter for grease cartridges.



Ordering details

Progressive feeder	Number of outlet pairs (pistons)	Number of maximum outlets
VGAB VPBM-3	3	6
VGAB VPBM-4	4	8
VGAB VPBM-5	5	10
VGAB VPBM-6	6	12

Function diagram

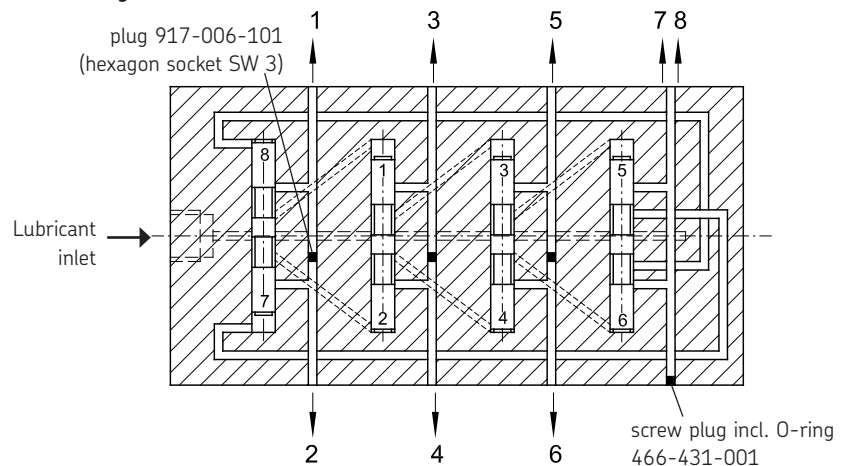

Grease Meter LAGM 1000E

Accurate grease quantity measurement for adequate lubrication

It is generally difficult to determine the correct quantity of grease when manually lubricating bearings, either using a grease gun or pump, which can result in either over- or under-greasing the bearing. That can negatively affect the bearing's service life and possibly result in machine breakdown.

The SKF grease meter LAGM 1000E accurately measures grease discharge in volume or weight, in both metric (cm^3 or g) and US units (fl. oz. or oz). It

has a high maximum pressure of 70 MPa (10,000 psi), making it ideal for use in combination with many types of grease guns and pumps.

- Measures grease discharge in volume or weight, making conversion calculations unnecessary
- High accuracy facilitates adequate bearing lubrication, reducing the risk of over- or under-greasing
- Suitable for all SKF bearing greases of consistency classes up to NLGI 3
- An oil and grease resistant rubber sleeve protects the electronics in case of impact

- The backlit LCD displays large and clear-to-read digits, including "low battery" indication
- Small, compact and lightweight design – only 0.3 kg (0.66 lb.)
- Corrosion-free aluminium housing
- Easy to install and use



Technical data

LAGP 400 (page 30)

Designation	LAGP 400		
Maximum volume per stroke	20 cm ³ (1.2 in ³)	Length	360 mm (14 in)
Material	Steel and polyethylene	Weight	0.35 kg (0.77 lb.)

VKN 550 (page 30)

Designation	VKN 550		
Description	Bearing grease packer	Other greases	NLGI class 000 to 2
Weight	1.8 kg (3.9 lb.)	Bearing range	
Material	Zinc plated, metal finish	– Inner diameter d	19 to 120 mm
Suitable greases	Approved for all SKF greases	– Outer diameter D	Max 200 mm

1077600 (page 31)

Designation	1077600		
Maximum pressure	40 MPa (5 800 psi)	Length	380 mm (14.9 in)
Volume/stroke	1.5 cm ³ (0.09 in ³)	Weight	1.5 kg (3.3 lb.)

LAGH 400 (page 31)

Designation	LAGH 400		
Maximum pressure	30 MPa (4 350 psi)	Length	370 mm (14.6 in)
Volume/stroke	approx. 0.8 cm ³ (0.049 in ³)	Weight	1.5 kg (3.3 lb.)

LAGG 400B (page 32)

Designation	Description
LAGG 400B	Battery driven grease gun (with 230 V charger)
LAGG 400B/US	Battery driven grease gun (with 110 V charger)
Maximum operating pressure	40 MPa (5 800 psi)
Min. burst pressure pump	80 MPa (11 600 psi)
Grease nozzle	4 jaws (suitable for nipples according to DIN 71412)
Operating temperature range	-15° to +50° C (5° to 120° F)
Grease NLGI	NLGI 000 to NLGI 2

Weight/dimensions:

Dimensions of grease gun including battery (L x H x D)	410 x 230 x 80 mm (16.2 x 9 x 3.2 in)
Weight of grease gun (including battery)	3.1 kg (6.8 lbs.)
Dimensions of carrying case (W x D x H)	480 x 390 x 130 mm (18.9 x 15.3 x 5.1 in)
Total weight (including case)	5.4 kg (11.9 lbs.)

PF-VPBM (page 33)

Designation	PF-VPBM
Lubricant	Grease up to NLGI grade 2
Reservoir capacity	450 ccm in 400 g cartridge G or W DIN 1284
Temperature range	-25° to +80° C (-13° to +176° F)
Mounting position	Any position
Delivery rate	2 ccm per stroke
Maximum back pressure	400 bars

LAGM 1000E (page 34)

Designation	LAGM 1000E		
Housing material	Aluminium, anodized	Accuracy	±3% from 0 – 300 bar
Weight	0.3 kg (0.66 lb.)		±5% from 300 – 700 bar
IP rating	IP 67	Selectable units	cm ³ , g, fl. oz. or oz.
Suitable greases	NLGI 0 – NLGI 3	Display lamp auto switch off	15 seconds after last pulse
Maximum operating pressure	70 MPa (10,000 psi)	Low battery	Indication on display
Maximum grease flow	1 000 cm ³ /min (34 fl. oz./min)	Battery type	1.5 V LR1 (2x) Alkaline
Thread connections	M10 × 1	Unit auto switch off	1 minute after last pulse
Display	Lit LCD (4 digits / 9 mm)		

Automatic lubricators

SYSTEM 24 Single Point Automatic Lubricator LAGD 125 and 60	38
SYSTEM 24 Single Point Automatic Lubricator LAGE 125 and 250	40
Relubrication Calculation Program DialSet 4.0	43
SYSTEM MultiPoint Automatic Lubricator LAGD 400	44
Oil Leveller LAHD 500 and 1000	45
Compact Greaser	46
Technical data	48



SKF SYSTEM 24 Single Point Automatic Lubricator LAGD 60 and LAGD 125

Reliable, cost effective automatic single point lubricator

The LAGD series of the SKF SYSTEM 24 family are automatic gas driven single point lubricators suitable for many applications. The units are supplied ready-to-use straight from the box and filled with a wide range of high quality SKF lubricants. Tool-free activation and time-setting allows easy and accurate adjustment of lubrication flow. .

- High reliability and dispense rate accuracy helps facilitate predetermined replacement date
 - Dispense rate setting is a simple part of the installation process and can be temporarily deactivated
 - Transparent lubricant container allows visual inspection of dispense rate
 - Intrinsic safety rating: ATEX approved for zone 0
 - Wide range of accessories is available
 - SKF SYSTEM 24 LAGD series is fully featured in SKF DialSet 4.0
- Gas driven lubricator is reliable in operation and flexible in application
 - Available in two sizes: 125 ml (LAGD 125) and 60 ml (LAGD 60) to suit most bearing lubrication applications
 - Compact size, permits installation in restricted areas.
 - Available filled with various high quality SKF greases and oils, to suit a wide range of bearing applications
 - Flexible time setting period ranging between 1 and 12 months
 - Ingress protection to IP 68 level allows the lubricator to be used in most dusty and wet environments
 - Wide operating temperature range to suit many applications



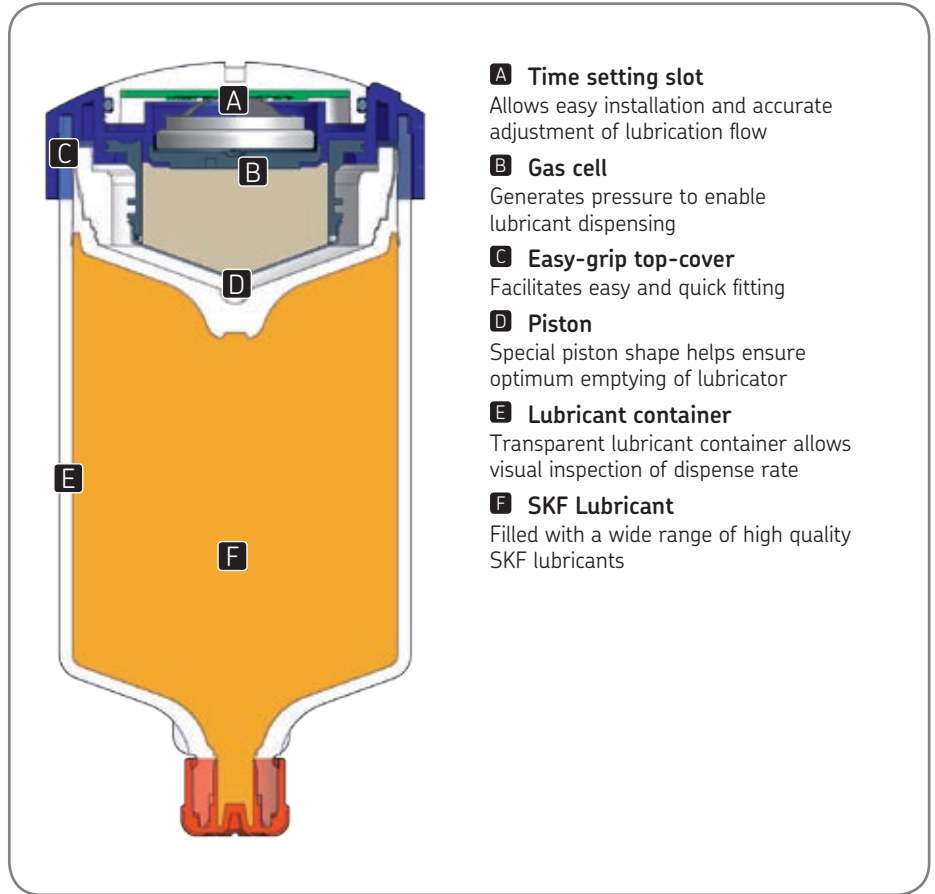

Ordering details

Designation	Description
LAGD 60/WA2	60 ml (2,03 fl oz. US) unit filled with LGWA 2 grease (multi-purpose EP type)
LAGD 125/WA2	125 ml (4,25 fl oz. US) unit filled with LGWA 2 grease (multi-purpose EP type)
LAGD 125/EM2	125 ml (4,25 fl oz. US) unit filled with LGEM 2 grease (high loads, slow rotations)
LAGD 125/GB2	125 ml (4,25 fl oz. US) unit filled with LGGB 2 grease (biodegradable)
LAGD 125/GB2	125 ml (4,25 fl oz. US) unit filled with LGGB 2 grease (biodegradable)
LAGD 125/GB2	125 ml (4,25 fl oz. US) unit filled with LGGB 2 grease (biodegradable)
LAGD 125/HP2	125 ml (4,25 fl oz. US) unit filled with LGHP 2 grease (high performance polyurea)
LAGD 125/FFP2 **	125 ml (4,25 fl oz. US) unit filled with LGFP 2 grease (food processing industry)
LAGD 60/HMT68 *	60 ml (2,03 fl oz. US) unit filled with LHMT 68 oil (medium temperature)
LAGD 125/HMT68 *	125 ml (4,25 fl oz. US) unit filled with LHMT 68 oil (medium temperature)
LAGD 125/HHT26 *	125 ml (4,25 fl oz. US) unit filled with LHHT 265 oil (high temperature)
LAGD 125/FHF15 */**	125 ml (4,25 fl oz. US) unit filled with LHFP 150 oil (food compatible, NSF H1 approved)
LAGD 125/FU */**	125 ml (4,25 fl oz. US) empty unit suitable for oil filling only

* Includes non-return valve

** Not available in USA and Canada

SKF SYSTEM 24

Single-point automatic lubricators

LAGE 125 and 250

Reliable, reusable lubricator system meets many needs

The LAGE series of the SKF SYSTEM 24 family are single point electro mechanical driven automatic lubricator systems. Suitable for a wide range of applications and operating conditions, the units are reliable and flexible in operation. Supplied ready to use straight from the box and ease of installation make the units a perfect compliment to the comprehensive range of SKF automatic lubricators.

- Temperature independent dispense rate, suitable for use in applications with changing temperatures
- Unlike gas powered units, a maximum discharge pressure of 6 bar can be achieved over the whole lubricant dispensing period
- Easy activation using a clearly marked dial helps minimize setting errors
- Transparent lubricant container allows visual inspection of dispense rate, while electro mechanical functions are indicated by simple red-green LED indicators
- Intrinsic safety rating: UL listed
- Wide range of accessories is available
- SKF SYSTEM 24 LAGE series is fully featured in SKF DialSet 4.0

Existing features

- Electro mechanical driven makes the unit high reliable in operation
- Available in two sizes: 122 ml (LAGE 125) and 250 ml (LAGE 250) to suit most bearing lubrication applications
- Remote mounting up to 3 meters (10 ft) for grease filled units and 5 meters (15 ft) for oil filled units allows lubrication of bearings in areas with high ambient temperatures, excessive vibration or hazardous environments
- Available filled with various high quality SKF greases and oils, to suit a wide range of bearing applications
- Refill sets consisting of a canister filled with SKF grease or oil and a battery pack help ensure reliable lubricator operation
- Flexible user adjustable dispense settings of 1, 3, 6, 9, or 12 months for use in many different applications
- Ingress protection to 65 IP level allows the lubricator to be used in many dusty and wet environments



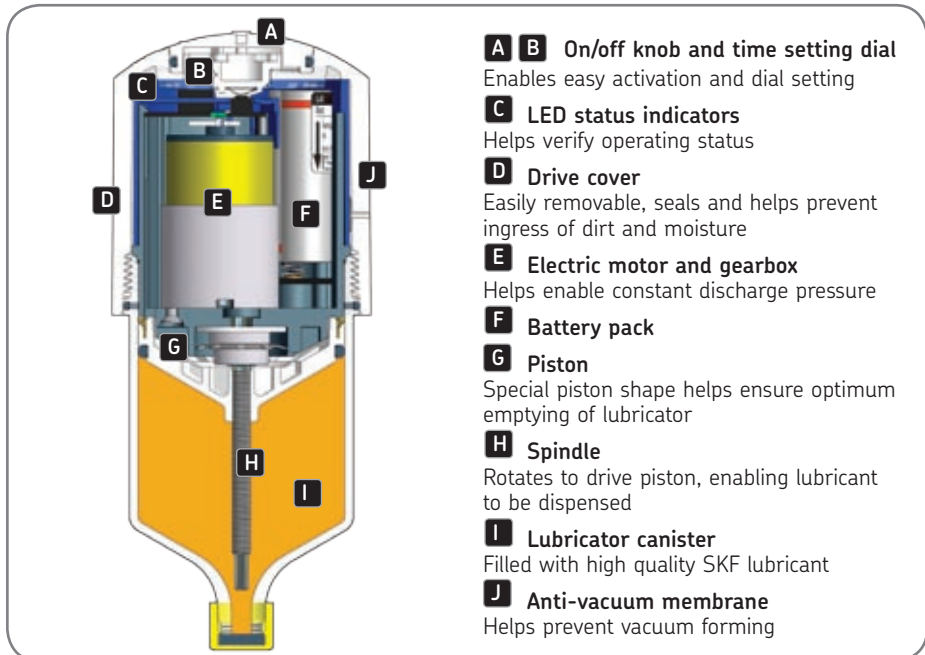

- A B On/off knob and time setting dial**
Enables easy activation and dial setting
- C LED status indicators**
Helps verify operating status
- D Drive cover**
Easily removable, seals and helps prevent ingress of dirt and moisture
- E Electric motor and gearbox**
Helps enable constant discharge pressure
- F Battery pack**
- G Piston**
Special piston shape helps ensure optimum emptying of lubricator
- H Spindle**
Rotates to drive piston, enabling lubricant to be dispensed
- I Lubricator canister**
Filled with high quality SKF lubricant
- J Anti-vacuum membrane**
Helps prevent vacuum forming

Ordering details

Designation	Lubricant	Description	Product
Greases			
LAGE 125/WA2 LAGE 250/WA2 LGWA 2/EML125 LGWA 2/EML250	LGWA 2	Multi-purpose EP type grease	Complete unit 125 Complete unit 250 Refill set 125 Refill set 250
LAGE 125/EM2 LAGE 250/EM2 LGEM 2/EML125 LGEM 2/EML250	LGEM 2	High loads, slow rotations	Complete unit 125 Complete unit 250 Refill set 125 Refill set 250
LAGE 125/HB2 LAGE 250/HB2 LGHB 2/EML125 LGHB 2/EML250	LGHB 2	High temperature, loads, plain bearing	Complete unit 125 Complete unit 250 Refill set 125 Refill set 250
LAGE 125/HP2 LAGE 250/HP2 LGHP 2/EML125 LGHP 2/EML250	LGHP 2	High performance polyurea	Complete unit 125 Complete unit 250 Refill set 125 Refill set 250
LAGE 125/FP2 LAGE 250/FP2 LGFP 2/EML125 LGFP 2/EML250	LGFP 2	Food processing industry	Complete unit 125 Complete unit 250 Refill set 125 Refill set 250
Oils			
LAGE 125/HMT68 LAGE 250/HMT68 LHMT 68/EML125 LHMT 68/EML250	LHMT 68	Medium temperature oil	Complete unit 125 Complete unit 250 Refill set 125 Refill set 250
LAGE 125/HHT26 LAGE 250/HHT26 LHHT 265/EML12 LHHT 265/EML25	LHHT 265	High temperature oil	Complete unit 125 Complete unit 250 Refill set 125 Refill set 250
LAGE 125/HFP15 LAGE 250/HFP15 LHFP 150/EML12 LHFP 150/EML25	LHFP 150	Food compatible, NSF H1 approved oil	Complete unit 125 Complete unit 250 Refill set 125 Refill set 250

Automatic lubricators

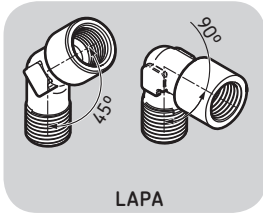

LAPA

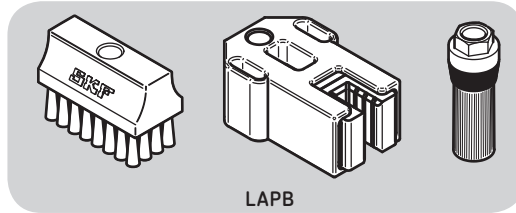

LAPB

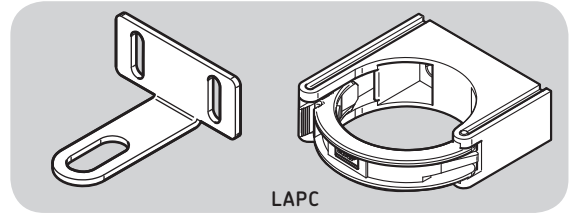

LAPC

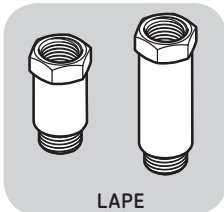

LAPE

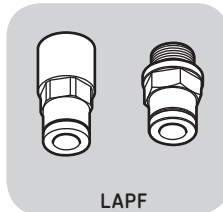

LAPF



LAPG

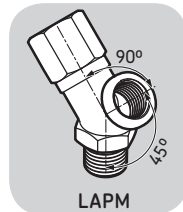

LAPM

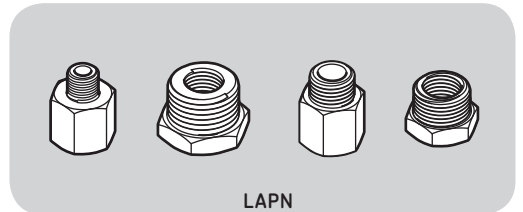

LAPN

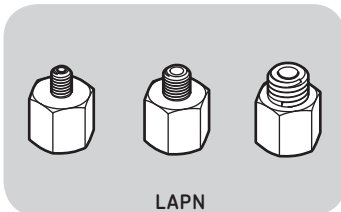

LAPN

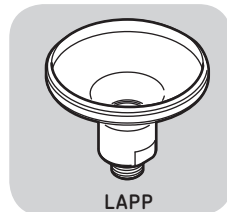

LAPP

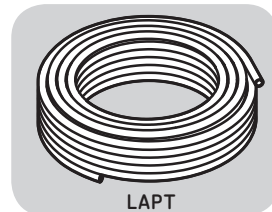

LAPT

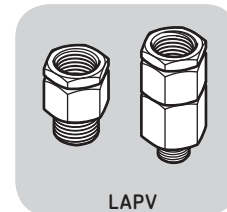

LAPV



LAGE 1-BAT

Accessories ordering details

Designation	Description	Designation	Description
LAPA 45	Angle connection 45°	LAPN 1/8	Nipple G 1/4 – G 1/8
LAPA 90	Angle connection 90°	LAPN 1/2	Nipple G 1/4 – G 1/2
LAPB 3x4E1 *	Brush 30 × 40 mm	LAPN 1/4	Nipple G 1/4 – G 1/4
LAPB 3x7E1 *	Brush 30 × 60 mm	LAPN 1/4UNF	Nipple G 1/4 – 1/4 UNF
LAPB 3x10E1 *	Brush 30 × 100 mm	LAPN 3/8	Nipple G 1/4 – G 3/8
LAPB 5-16E *	Elevator brush, 5 – 16 mm gap	LAPN 6	Nipple G 1/4 – M6
LAPB D2 *	Brush round Ø 20 mm	LAPN 8	Nipple G 1/4 – M8
LAPC 13	Bracket	LAPN 8x1	Nipple G 1/4 – M8 × 1
LAPC 50 **	Clamp	LAPN 10	Nipple G 1/4 – M10
LAPC 63 ***	Clamp	LAPN 10x1	Nipple G 1/4 – M10 × 1
LAPE 35	Extension 35 mm	LAPN 12	Nipple G 1/4 – M12
LAPE 50	Extension 50 mm	LAPN 12x1.5	Nipple G 1/4 – M12 × 1,5
LAPF F1/4	Tube connection female G 1/4	LAPP 2E **	Protection base
LAPF M1/4	Tube connection male G 1/4	LAPP 3E **	Protection cover
LAPF M1/8	Tube connection male G 1/8	LAPP 63 ***	Support flange
LAPF M3/8	Tube connection male G 3/8	LAPP 63V ***	Support flange with non-return valve
LAPG 1/4	Grease nipple G 1/4	LAPT 1000	Flexible tube, 1 000 mm long, 8 × 6 mm
LAPM 2	Y-connection	LAPT 5000 ***	Flexible tube, 5 000 mm long, 8 × 6 mm
LAPM 4 **	Manifold (4 to 1)	LAPV 1/4	Non return valve G 1/4
		LAPV 1/8	Non return valve G 1/8
		LAGE 1-BAT ***	Battery pack

* Suitable for use with oil filled SYSTEM 24 LAGD and LAGE units only

** Suitable for use with LAGD 60 and LAGD 125 SYSTEM 24 only

*** Suitable for use with LAGE 125 and LAGE 250 SYSTEM 24 only

Relubrication Calculation Program DialSet 4.0

Accurate calculation of relubrication intervals

DialSet is a calculation program, which easily calculates the correct relubrication intervals settings. After selecting the criteria and grease relevant to your application, the program provides you with the correct settings for your SKF automatic lubricators.

- Selecting the operating conditions of your application, vertical shaft, outer ring rotation and shock loads, allows accurate calculation of the relubrication intervals
- Calculations are based on SKF lubrication theories
- Calculated lubrication interval depends on the properties of the selected grease, minimizing the risk of under- or over-lubrication and optimizing grease consumption
- Calculations are based on SKF automatic lubrication systems grease dispense rates, allowing the recommendation of the correct lubricator setting
- Recommended grease quantity depends on the grease replenishment position; side or W33 for optimum grease consumption
- Includes a complete list of the SKF SYSTEM 24 family accessories

DialSet 4.0 on CD-ROM

DialSet 4.0 is available on CD-ROM with calculation in 10 languages:

English, French, German, Italian, Spanish, Swedish, Portuguese, Russian, Chinese and Thai.

The program is suitable for PC's working with MS Windows 98 and later. This CD-ROM can be ordered from SKF under designation MP3506..

DialSet 4.0 online

In addition to the downloadable PDA/PPC and the CD-ROM versions, SKF also offers you DialSet 4.0 online in English language.

The program is available at www.mapro.skf.com.

After filling in your application's conditions, calculations are made online and the program provides you with a printable relubrication interval recommendation.

DialSet 4.0 for PDA/PPC

If you own a PDA or a PPC, you can now calculate the correct relubrication intervals on-site. From www.mapro.skf.com you can now download, free-of-charge, the PDA/PPC version of SKF's re-lubrication calculation program DialSet 4.0 in English language.

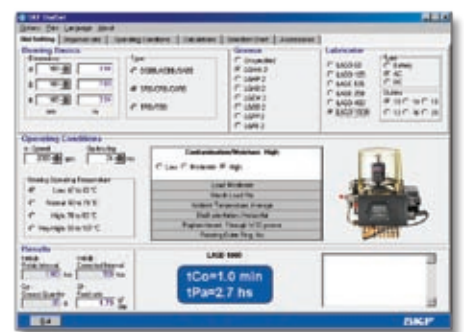
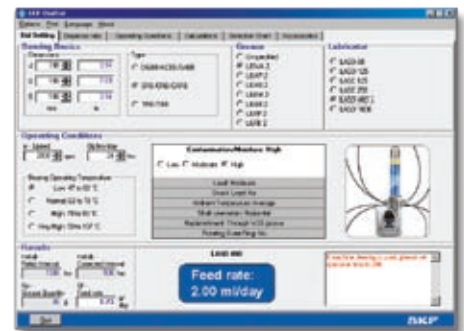

SYSTEM MultiPoint Automatic Lubricator LAGD 400

Multiple grease lubrication points made easy

The lubrication of bearings with the correct type and quantity of grease is essential for trouble-free operation. Research has shown that 36% of all bearings fail prematurely due to incorrect lubrication. Especially for

installations with multiple lubrication points, this can be a time-consuming and costly process. SYSTEM MultiPoint, SKF's centralized automatic lubricator, is the most user-friendly and cost-effective automatic lubricator for multiple grease lubrication points available today. Its compact design, combined with electronically controlled

accuracy, makes it an excellent solution for longer bearing life and increased uptime of your machinery.

- Do-it-yourself centralized lubrication system
- Up to 8 feed lines
- Easy-to-use
- DialSet 4.0 included: SKF's re-lubrication calculation program allows accurate calculation of the correct re-lubrication intervals
- Long feed lines (maximum up to 5 m / 16 ft)
- Electronic setting and read-out of control parameters
- Alarm function for blocked feed lines and empty cartridge
- Machine steering (i.e. lubricator only operates while machine is running)
- High-pressure capability (40 bar / 600 psi)
- Tested and approved with all SKF greases
- Uses standard SKF grease cartridges (420 ml)
- Ready for use, all accessories included



Oil Levellers LAHD 500 and 1000

Automatic adjustment for optimal oil lubrication level

SKF Oil Levellers, LAHD 500 and LAHD 1000, are designed for automatic adjustment of the optimal oil lubrication level within a bearing housing, gear box, crank case or similar oil bath lubrication application. Not usually possible, SKF oil levellers allow you to effectively adjust the correct oil level during running conditions, optimizing machine performance and increasing the service life of the applications. Furthermore, they automatically compensate for oil leakage and offer the possibility of visual inspection of the oil level.

How it works

The SKF oil leveller consists of two communicating oil reservoirs.

The lower reservoir is in direct contact with the application and hence its oil level is the same as the oil level inside the application.

Through a ventilation hole, the lower reservoir is also in direct contact with the ambient air. The upper reservoir is an airtight container storing replacement oil. Through its extended neck, which dips into the oil of the lower reservoir, the two reservoirs are in direct contact with each other. However, oil can only flow from the upper to the lower reservoir once the oil level in the lower reservoir goes below the pre-set level, allowing air to flow through the extended neck to the upper reservoir.

- Optimally maintained oil level provides adequate lubrication
- Easy visual inspection
- Extended re-lubrication intervals
- LAHD 1000 compensates for evaporation losses of up to 1 liter of lubricating oil
- Oil must be refilled manually



Compact Greaser

Innovation for linear guides

Compact greaser for linear guide systems

- Up to 5 lubricant outlet ports
- Suitable for grease, NLGI grades 000 to 2
- Increases the service life of linear guides
- Increases operating reliability
- Cuts maintenance and service costs

Compact, automatic, dependable

With our compact greaser we have succeeded in developing an automatic, electrically driven centralized lubrication system especially designed for linear guide systems.

The ETP compact greaser does not require a separate control unit. The machine's control system provides the electric power and control functions. Unlike Permadosse dispensers, the compact greaser lubricates only when the machine is running.

The compact greaser is easy to install due to its small dimensions and low weight. With its bayonet holder, it's also easy to change the reservoir whenever necessary.

Depending on lubricant consumption, the grease could last for up to five years of operation.



Ordering details

Order no.	Number of outlets	Outlet assignment	Metering (mm ³) outlet no.				
			1	2	3	4	5
VGPG ETP2	2	1 and 3	15	X	15	X	X
VGPG ETP3	3	1, 3 and 4	15	X	15	15	X
VGPG ETP4	4	1 to 4	15	15	15	15	X
VGPG ETP5	5	1 to 5	15	15	15	15	15

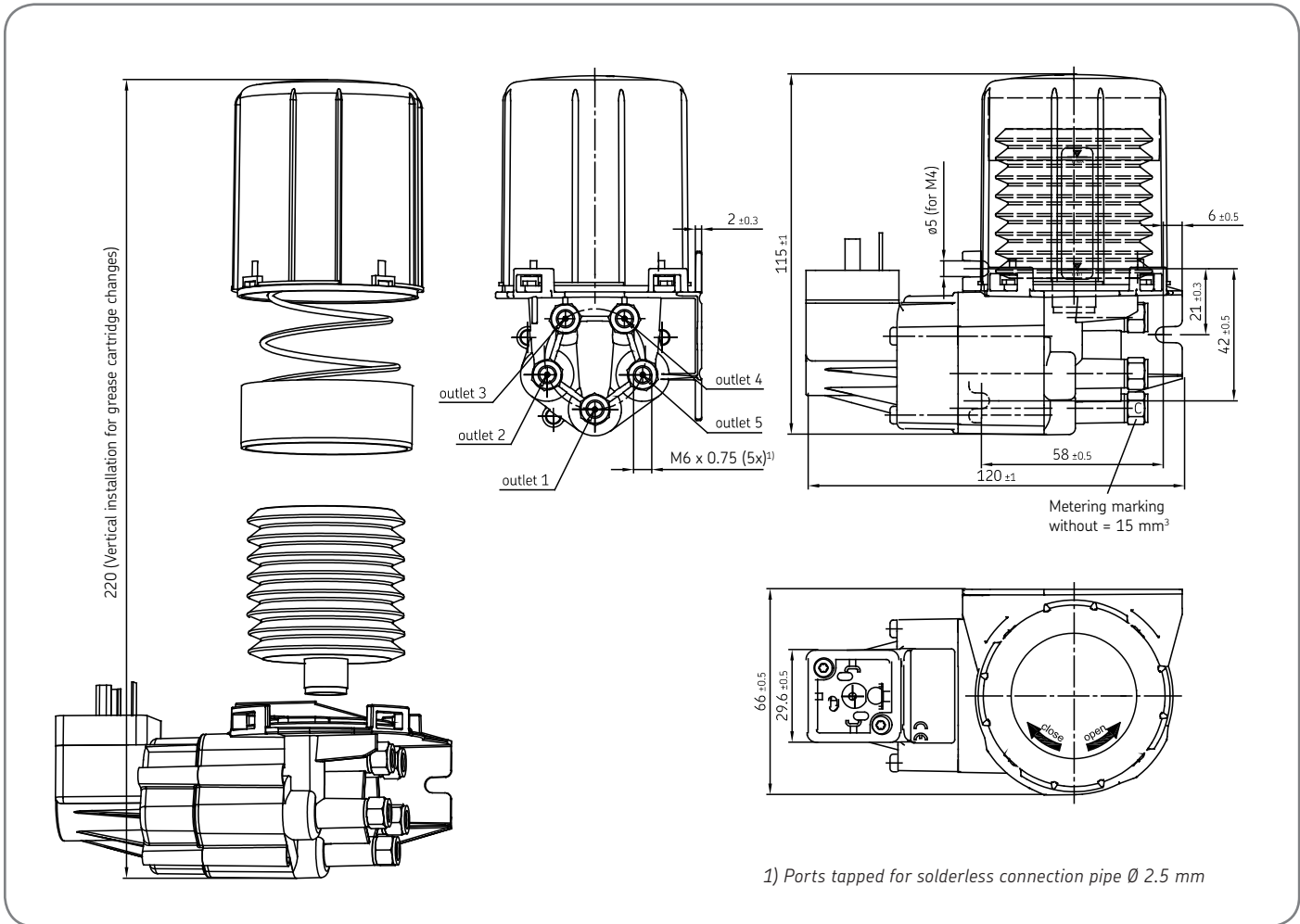

Accessories (to be ordered separately)

PA tube, 1.5 m with socket union on one side, filled with grease

Order no. VGKG 995-001-197+BF5

Socket union, order no. VGKG 402-612

Tapered sleeve, order no. VGKG 402-611

Reinforced socket, order no. VGKG 402-603

Adaptors for 2.5 mm diam. tube:

M6 Order no. VGKG 402-004

M6 x 0.75 Order no. VGKG 402-003

M8 x 1 Order no. VGKG 402-006

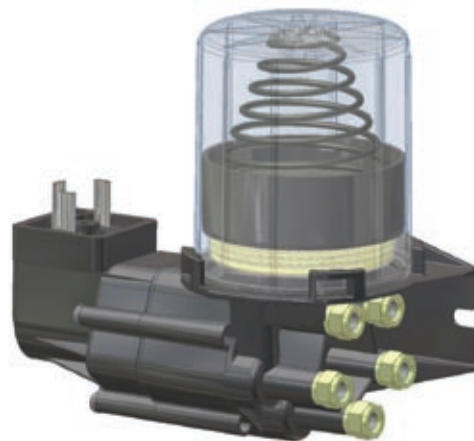

Compact greaser ETP

Technical data

LAGD 125 and 60 (page 38)

Grease capacity	LAGD 125 125 ml (4.25 fl. oz.) LAGD 60 60 ml (2.03 fl. oz.)		
Nominal emptying time	Adjustable; 1 – 12 months	Intrinsically safe approval	II 1GD EEx ia IIC T6 T85° C
Ambient temperature range	–20° to 60° C (–5° to 140° F)		I M1 EEx ia I
Maximum operating pressure	5 bar (75 psi)	EC Type Examination Certificate	Kema04ATEX1275X
Drive mechanism	Gas cell producing inert gas	Protection class	IP 68
Connection thread	G 1/4	Recommended storage temperature	20° C (70° F)
Maximum feed line length with:		Storage life of lubricator	2 years
– grease	300 mm (11.8 in)	Weight	LAGD 125 approx 200 g (7.1 oz.)
– oil	1 500 mm (59.1 in)		LAGD 60 approx 130 g (4.6 oz.)
			Lubricant included

LAGE 125 and 250 (page 40 – 41)

Grease capacity	LAGE 125 122 ml (4.1 fl. oz US) LAGE 250 250 ml (8.5 fl. oz US)		
Emptying time	User adjustable: 1, 3, 6, 9 and 12 months	Intrinsic safety rating	UL listed T code 59°C – Category BAYZ – 92UM
Lowest grease purge			Lubricant dispensing equipment for use in hazardous locations
– LAGE 125	0.3 ml per day (0.01 fl. oz US)		Class I, Division II,
– LAGE 250	0.7 ml per day (0.02 fl. oz US)		Group A, B, C, D
Highest grease purge			Class II, Division II, Group F & G
– LAGE 125	4.1 ml per day (0.13 fl. oz US)		Class III
– LAGE 250	8.3 ml per day (0.28 fl. oz US)		
Ambient temperature range	0 °C (–10°C peak) to 50 °C (32 °F (14 °F peak) to 122 °F)	Protection class	IP 65
Maximum operating pressure	5 bar (75 psi)	assembled lubricator	4,5V 2,7 Ah –
Drive mechanism	Electro–mechanical	Battery pack	Alkaline manganese
Connection thread	R ¼	Recommended storage temperature	20 °C (70 °F)
Maximum feed line length with:		Storage life of lubricator	3 years ** (2 years for LGFP 2 and Oils)
– grease	Up to 3 meters (10 ft) *	Total weight	
– oil	Up to 5 meters (16 ft)	– LAGE 125	635 g (22,5 oz)
LED status indicators	operating, purging lubricant, empty, malfunction	– LAGE 250	800 g (28,2 oz)

* The maximum feed line length is dependent on ambient temperature, grease type and back pressure created by the application.

** Storage life is 3 years from production date, which is printed on the side of the canister. The canister and battery pack may be used even at 12 months setting if activated 3 years from production date.

LAGD 400 (page 44)

Designation	LAGD 400		
Content	8–outlet lubricator 20 m tubing Quick connectors for application side 2 Y–connectors LGMT 2 / 0.4 grease cartridge SKF's DialSet program	Volume	0.1 – 10 cm ³ /day (0.003 – 0.35 fl. oz./day) Per outlet Approximately 0.6 – 65 g/week (0.02 – 2.3 oz./week)
Number of feed-lines	1 – 8	Power	110–240V AC, 50–60Hz or 24V DC
Maximum pressure	40 bar (600 psi)	Alarms	Blocked feed lines, empty cartridge; Internal and external
Suitable grease	NLGI 1, 2 and 3	External steering	External relay steering
Maximum length of feed lines	5 m (16 ft.)	IP rating	54
Ambient temperature	0° – 50° C (32° – 120° F)	Lubrication tubes	20 m (65 ft.), Nylon, 6 × 1.5 mm (1/4 × 0.06 in)
Drive mechanism	Electro–mechanical	Connection thread	G 1/4
		Height	530 mm (21 in)

LAHD 500 and 1000 (page 45)

Designation	LAHD 500 / LAHD 1000		
Boundary dimensions		Permissible humidity	0 – 100%
– LAHD 500	Ø 91 mm × 290 mm high (3.6 × 11.4 in)	Length of connecting tube	600 mm (23.5 in)
– LAHD 1000	Ø 122 mm × 290 mm high (4.8 × 11.4 in)	Connection thread	G 1/2
Reservoir volume		Tube material	Polyurethane
– LAHD 500	500 ml (17 fl. oz.)	O-ring material	NBR – 70 shore
– LAHD 1000	1 000 ml (34 fl. oz.)	Gaskets	NBR – 80 shore 6 pieces
Container material	Polycarbonate / aluminium	Other material	Aluminum, bronze, stainless steel
Allowed temperature range	– 20° to 125° C (–4° to 255° F)	Suitable oil types	Mineral and synthetic oils

Compact greaser (page 46)

Number of outlet ports	2, 3, 4, or 5	Starting current maximum	1 A
Operating pressure	6 bars	Operating temperature	15° to 40° C (59° to 104° F)
Power	24 V DC	El. connection	DIN EN 175301-803
Actuation duration	7 min	Reservoir	80 cm ³ cartridge
Pause interval minimum	30 min	Lubricant	Grease, NLGI grade 000 to 2
Power consumption	24 W		

Pre-engineered systems



Fan and industrial application units: grease	52
SYSTEM MultiPoint Automatic Lubricator	53
Mini-pump units	54
Battery-powered piston pump	55
Grease injectors VL-1, VL-11 and VL-32	56
VSP Modular progressive feeders	58
Duoflex™ lubricant distributor	60
Fan and industrial application units: oil	61
Single-circuit pumps	64
Safeflow™ oil flowmeters	66
Level switches	67
Tabletop chain lubrication systems	70
Compact units for oil	72
Piston distributors	73
Flow monitors and sensors for oil	76
Technical data	78

Fan and industrial application units: grease

Fan units – grease

SKF has taken the knowledge and expertise of Vogel Lubrication and developed three solutions for grease-lubricated fan and blower bearings.

Fan and blower bearings are often critical to the operation of industrial manufacturing facilities. In some cases, they are in hard-to-access locations. The SKF grease lubrication units for fans can help users ensure that these bearings are being lubricated properly.

These units are designed to deliver grease from 2 to 20 points consistently and effectively, providing the right amount of lubrication for extended bearing life.

Applications

- Industrial fans
- Blowers
- Motors
- Pumps

Features

- Durable construction
- Easy installation
- Highly effective lubrication monitoring with indicator pins on each metering chamber
- Simple monitoring of system pressure with switch at end of line



VGPA KFGS10-5W1-02-V6

VGPA KFGS30-5W1-02-V6

- Fully-automated operation with use of electronic control system
- Central monitoring of feeder points possible with progressive feeder cycle sensor
- 6 mm secondary lines avoid increased pressure of overall system
- Built in reservoir agitation prevents grease separation and eliminates entrained air in the system
- 96-264VAC, 50/60 Hz, 12 or 24 VDC available upon request



VGPA KFGS10-5W1-20-V33

Ordering details

Part no.	Reservoir capacity (Liters)	Low level switch	Pressure gauge	Filter	Controls	Monitoring	Enclosure	Nylon tubing installation kit
VGPA KFGS10-5W1-XX-V6	2	•	•	•	•	•		•
VGPA KFGS10-5W1-XX-V8	2	•	•	•	•			•
VGPA KFGS10-5W1-XX-V32	2	•	•	•	•		•	•
VGPA KFGS10-5W1-XX-V33	2	•	•	•	•	•	•	•
VGPA KFGS30-5W1-XX-V6	6	•	•	•	•	•		•
VGPA KFGS30-5W1-XX-V8	6	•	•	•	•			•
VGPA KFGS30-5W1-XX-V32	6	•	•	•	•		•	•
VGPA KFGS30-5W1-XX-V33	6	•	•	•	•	•	•	•

XX = the number of points required. When ordering, specify the number of points (02-20). Example: VGPA KFGS10-5W1-02-V8

• = components contained in the unit

SYSTEM MultiPoint Automatic Lubricator LAGD 1000

Centralized lubrication for up to 20 lubrication points

The SKF SYSTEM MultiPoint automatic lubricator LAGD 1000 is a reliable centralized lubrication system offering lubrication solutions for bearings and machinery. The LAGD 1000 uses a high-pressure pump and a progressive feeder for lubricating from 6 to 20 lubrication points. Supplied as a complete ready-to-use kit, all accessories required are included in the box.

- Suitable for greases from NLGI 000 to NLGI 2, offers high flexibility in types of lubricants that can be used
- Sturdy, robust design with IP65 rating, suitable for most industrial environments
- Transparent reservoir, allows visual monitoring of lubricant level
- Progressive divider so that exactly the same amount of grease reaches each lubrication point
- 1 liter (33.8 fl. oz.) refillable grease container, increases intervals between refilling
- Extensive programming options, allowing flexibility to suit most applications
- Empty container alarm, helps reduce the risks associated with lack of lubrication
- Wide temperature range, helps meet a variety of tough operating conditions year round
- Cycle switch function (not on battery version) notifies operator of blocked outlets so that proper action can be taken
- Battery powered version available, no need for external power source, can be used most anywhere

Note: To order, specify power source and number of points.

Examples:
 LAGD 1000 / B12 Battery powered
 LAGD 1000 / DC12 24V DC
 LAGD 1000 / AC12 110-240V AC

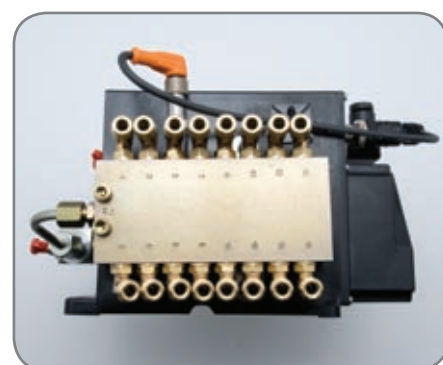

Mini-pump units, group KFA/KFAS

Pumps belonging to the KFA(S) series come with a maximum of 2 outlet ports for the connection of 2 independent lube circuits. A separate pump element is required for each outlet.

Three pump elements with different delivery rates are available so that the volume of grease can be adjusted to the needs of the individual circuits. This feature ensures that every lube point is supplied with an adequate amount of grease in each lubrication cycle.

Control is provided by an integral IG502-I control and monitoring unit; it can be operated in a time- or load- (pulse) dependent mode, and with or without monitoring.

The control system provides the following advantages:

- Non-volatile memory with PIN-code protection
- Storage of residual interval and lubricating cycle
- Storage of fault signals (diagnosis memory)
- Data save in event of a power failure
- Connection for external pushbutton
- Connection for inductive cycle switch
- Interval and contact times can be set independent of each other, even with monitored systems
- Electrical connections easy via 7-pole plug connector

Please order cable harness separately. Contact SKF for ordering information.



Ordering details

Piston pump Order no.	Reservoir capacity (liters)	Grease filling including grease
VGBB KFA1	1	Via conical head nipple
VGBB KFAS1 (incl. control system)	1	Via topping-up pump

A "W" has to be appended to the order no. for pump units with filling level monitoring, order example: KFAS1-W

Ordering details

Pump elements Order no.	Delivery rate ¹⁾ (ccm/min)
VGAV KFA1.U1	2.0
VGAV KFA1.U2	1.5
VGAV KFA1.U3	1.0

The following has to be appended to the pump's order number:
for operating voltage, +912 (12 V DC), +924 (24 V DC)
Order example: VGBB KFAS1 +912

¹⁾ The indicated rates refer to the delivery of NLGI grade 2 grease at an operating temperature of 20°C and a back pressure of 50 bars. Temperatures and pressures that deviate from these figures lead to different delivery rates. The indicated values must be taken as a basis in the design of a centralized lubrication system.

Piston pump, series KFAS1-B

Battery-powered for grease up to NLGI grade 2

The KFAS-Battery unit was developed for the automatic lubrication of hard-to-reach lube points without main power.

The completely autonomous unit with integrated control system and feeder can supply as many as 20 lube points with exactly metered quantities of grease.

Battery-powered

- No expensive electrical installations

Battery life is one year or one reservoir filling

- Foreseeable battery maintenance intervals
- Ecofriendly and easy disposal

Integrated control unit with visual and acoustic warning

- Reliable monitoring of battery and lubricant level

Integrated block feeder for 6 to 20 lube points

- Simple, low-cost installation

Operates at temperatures down to -10°C

- Dependable supply of grease regardless of temperature swings



Ordering details

Standard version with filling level monitoring
Order no.

VGBB KFAS1-B-W-3
VGBB KFAS1-B-W-4
VGBB KFAS1-B-W-5
VGBB KFAS1-B-W-6
VGBB KFAS1-B-W-7
VGBB KFAS1-B-W-8
VGBB KFAS1-B-W-9
VGBB KFAS1-B-W-10

Maximum number of outlet points

6
8
10
12
14
16
18
20

Weight including grease [kg]

6.7
6.9
7.1
7.3
7.5
7.7
7.9
8.1

Accessory kit for lube point connectors

Thread

M10 x 1
G 1/8
1/8 NPT

Up to 8 lube points
Order no.

VGKP 186-817.01
VGKP 186-819.01
VGKP 186-821.01

> 8 lube points
Order no.

VGKP 186-818.01
VGKP 186-820.01
VGKP 186-822.01

Grease injectors VL-1, VL-11 and VL-32

- For single line, high-pressure lubrication systems
- For dispensing lubricants compatible with fluorocarbons packings and viscosity up to NLGI No. 2
- Output is externally adjustable
- Indicator pin permits visual check of injector operation
- Individual injectors can be easily removed for inspection or replacement



VL-1 Single injector

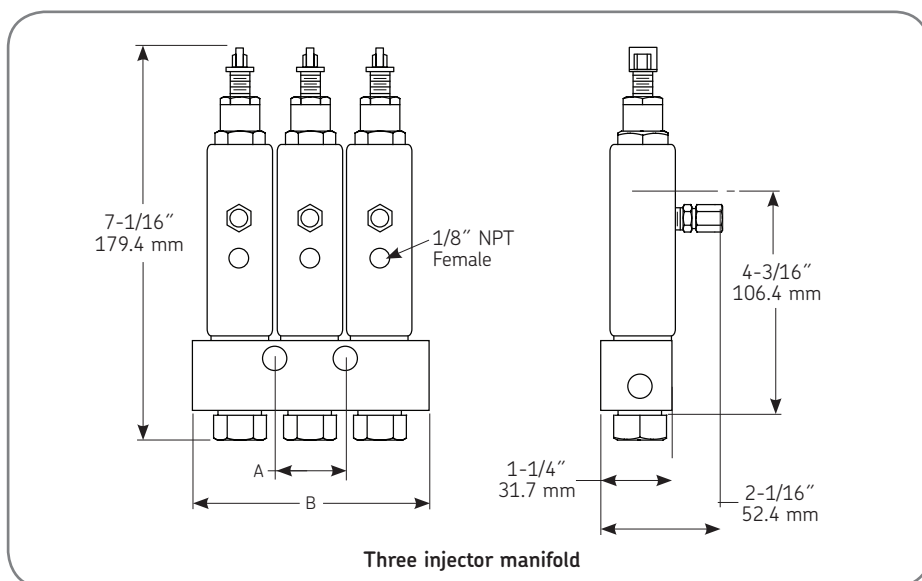

Three injector manifold

Available in 316 stainless steel for tough applications

VL-1 Specifications

Output		Operating pressure				Connections	
Min.	Max.	Min.	Max.	Typical	Vent	Manifold inlet	Injector outlet
0.131 cc	1.31 cc	127 bar	241 bar	172 bar	41 bar	3/8" NPTF	1/8" NPTF
0.008 ci	0.08 ci	1850 psig	3500 psig	2500 psig	600 psig	(F)	(F)

VL-1 Ordering details

Model	Type	Number of outlets	Dimension			
			A		B	
			in.	mm	in.	mm
VGAA VL-1-1	One injector manifold	1	Single mounting hole		2.5	63
VGAA VL-1-2	Two injector manifold	2	Single mounting hole		3	76
VGAA VL-1-3	Three injector manifold	3	1.25	32	4.25	108
VGAA VL-1-4	Four injector manifold	4	2.5	63	5.5	140
VGAA VL-1-5	Five injector manifold	5	3.75	95	6.75	171
VGAA VL-1-6	Six injector manifold	6	5	123	8	203
VGAA VL-1	Injector	Single injector / no manifold [3/8" NPTF (M) inlet]				
VGAA VL-1-M	Injector	Replacement for manifold injectors				



VL-11 Stand alone

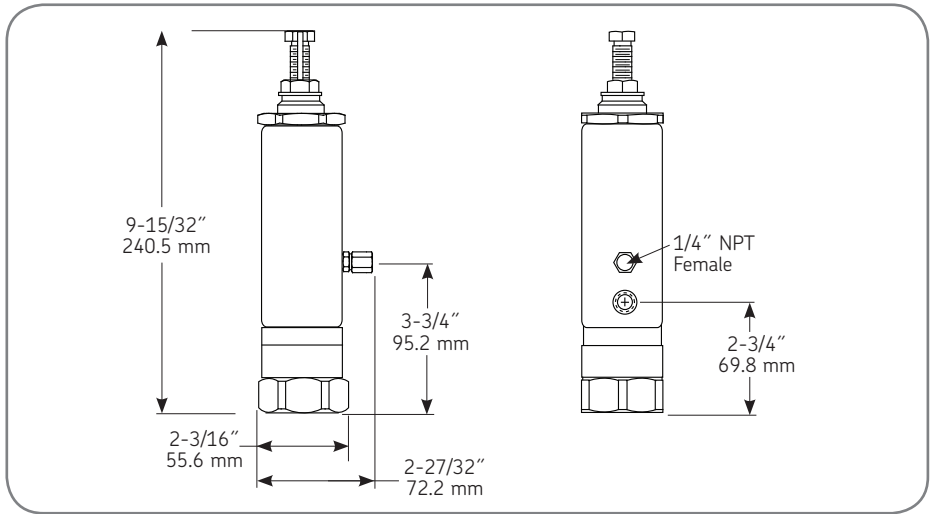

VL-11 Ordering details

Model VGAA VL-11-85497

Available only as a carbon steel single injector with 1/2" NPTF female insert

VL-11 Specifications

Output		Operating pressure				Connections	
Min.	Max.	Min.	Max.	Typical	Vent	Manifold inlet	Injector outlet
0.82 cc	8.2 cc	69 bar	241 bar	172 bar	55 bar	1/2" NPTF (F)	1/4" NPTF (F)
0.05 ci	0.5 ci	1000 psig	3500 psig	2500 psig	800 psig		

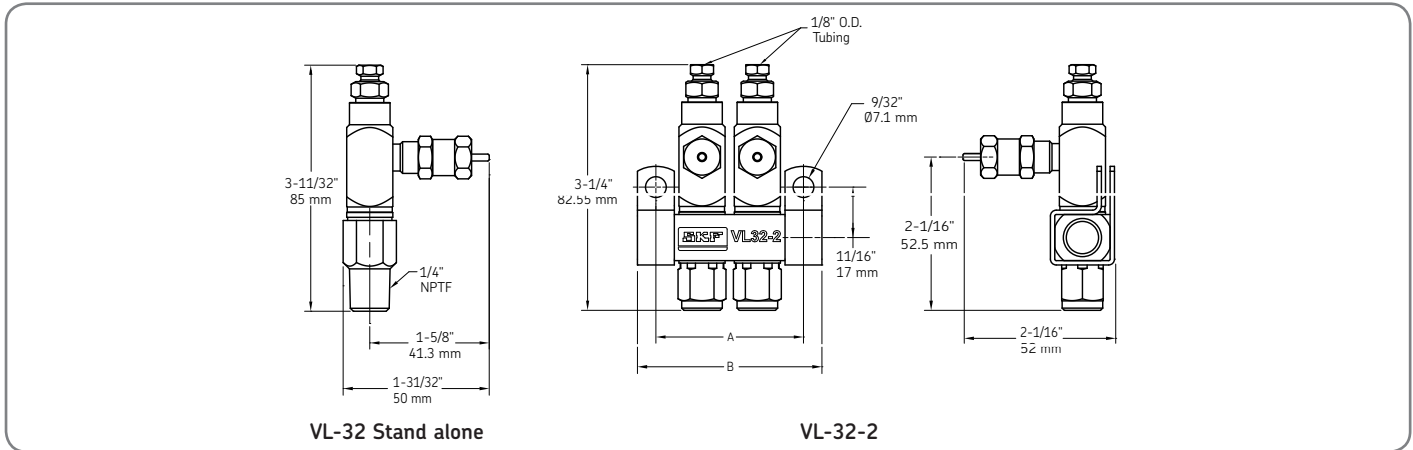

VL-32 Stand alone

VL-32-2

VL-32 Specifications

Series	Output		Operating pressure			
	Min.	Max.	Min.	Max.	Typical	Vent
VGAA VL-32	0.001 cu. in.	.008 cu. in.	1200 psig	3500 psig	1500 psig	200 psig
	0.016 cc	.131 cc	83 bar	241 bar	103 bar	14 bar

VL-32 Ordering details

Model	Number of outlets	Connections		Dimensions			
		Manifold inlet	Injector outlet	A		B	
				in.	mm	in.	mm
VGAA VL-32-1	1	1/4" NPTF (F)	1/8" O.D. tube	1.25	32	1.75	44
VGAA VL-32-2	2	1/4" NPTF (F)	1/8" O.D. tube	2	51	2.5	63
VGAA VL-32-3	3	1/4" NPTF (F)	1/8" O.D. tube	2.75	70	3.25	83
VGAA VL-32-4	4	1/4" NPTF (F)	1/8" O.D. tube	3.5	89	4	102
VGAA VL-32	1	1/4" NPTF (F)	1/8" O.D. tube	Single injector / no manifold			
VGAA VL-32-M				Replacement for manifold injectors			

VSP Modular progressive feeders

Modular and flexible for grease systems up to 4,000 PSI

Each VSP assembly includes a minimum of three distributor segments, a base plate, an inlet section, and an end section.

Twin piston sections are ported to create separate outputs for two lube points. Single sections combine the output from both ends of the piston and send it to a single lube point.

Cross-porting or singling sections can be done to increase the flow to a single point or to lubricate an odd number of points.

A bypass section can be used to provide grease to additional lubrication points or it can eliminate an entire piston section.

Features

- Precise monitoring
- Modular design for flexibility
- Simple installation and operation
- Individual valve adjustability
- Lubricate up to 16 points per assembly
- “Drop-in” replacement for competitive valve assemblies
- SAE type fluorocarbon o-ring sealed piston bores
- 90 durometer fluorocarbon o-rings standard on all valve and intermediate sections
- Corrosion protected steel material

VSP feeder specifications

Maximum cycle rate	Maximum pressure	Maximum temperature	Lubricant
60 / minute with cycle pin	4000 PSI	200° F	Oil or grease
200 / minute without cycle pin (or with Prox cycle switch)	4000 PSI	200° F	Oil or grease

VSP dimension details

Number of sections	L1 dimension
3	90.881 mm
4	114.300 mm
5	137.718 mm
6	161.138 mm
7	184.556 mm
8	207.975 mm

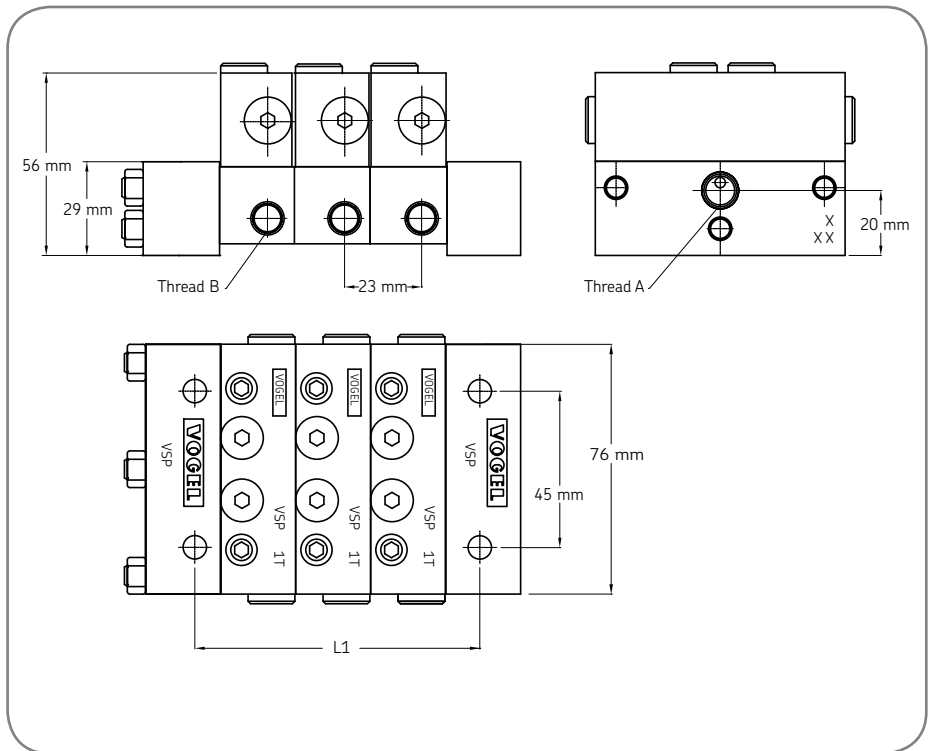

VSP feeder ordering details

(Example: VGAB VSPA-4-15-S-CB)

VGAB VSP

X -

X -

XX -

XXX -

XX

S = SAE - straight thread
o-ring seal
A = NPT - NPSF pipe thread
G = BSPP - British parallel
pipe O-ring seal (ISO1179)

**Inlet / Outlet
port type**

3 = three
4 = four
5 = five
6 = six
7 = seven
8 = eight

**Number of
sections**

BP = blind element
05 = .005 cu. in. (.082 ccm)
10 = .010 cu. in. (.164 ccm)
15 = .015 cu. in. (.246 ccm)
20 = .020 cu. in. (.328 ccm)
25 = .025 cu. in. (.410 ccm)
30 = .030 cu. in. (.492 ccm)
35 = .035 cu. in. (.574 ccm)
40 = .040 cu. in. (.656 ccm)

**Valve
capacity**

T = twin valve
S = single valve, RH outlet
SL = single valve, LH outlet
TZR = twin valve, cycle pin right
SZR = single valve, cycle pin right, RH outlet
D = single valve, cycle pin right, LH outlet
TZL = twin valve, cycle pin left
J = single valve, cycle pin left, RH outlet
K = single valve, cycle pin left, LH outlet

**Type of
valve block**

CR = right hand side
CL = left hand side
CB = both side

**Crossporting
option**

Duoflex™ lubricant distributor

For dual-line central lubrication systems

Features of lubricant distributors

Dual-line distributors are used in dual-line centralized lubrication systems for grease up to NLGI grade 3 as well as for oil conforming to ISO VG with an operating viscosity greater than 50 mm²/s.

- Low pressure losses due to large distributor bores make it possible to combine a number of distributors in a row
- Infinitely adjustable 0-5.0 cm³/ stroke
- Compact design
- Easy to combine ports (doubling dosing volume)
- Dual-line distributors can be equipped with piston detectors at any time for the purpose of checking whether the dosing piston is functioning
- Piston detectors can be added at any time
- Up to 8 lube points can be supplied with lubricant by one distributor
- High lubricating reliability of distributors due to a maximum operating pressure of 400 bars
- Lubricant distributors can be combined
- Replaces other manufacturer's dual line valves



Distributor, 2-port type



Distributor, 4-port type



Ordering details

Part no.	Max outlets	Output range per stroke	Supply connections	Discharge connections
VGAC 546-101-015-V1	2	.16 - 4.92 cc	3/8 - 18 NPSF	1/4 - 18 NPSF
VGAC 546-201-015-V1	4	.16 - 4.92 cc	3/8 - 18 NPSF	1/4 - 18 NPSF
VGAC 546-301-015-V1	6	.16 - 4.92 cc	3/8 - 18 NPSF	1/4 - 18 NPSF
VGAC 546-401-015-V1	8	.16 - 4.92 cc	3/8 - 18 NPSF	1/4 - 18 NPSF

Fan and industrial application units: oil

Fan units – circulating oil

The SKF circulating oil lubrication unit is ideal for rolling bearings on industrial fans where high speeds and/or high temperatures can preclude the use of grease. These units deliver a continuous flow of cooled and filtered oil directly to the bearing. The metered pump flow is matched to the bearing and housing size, preventing oil leaks and excessive heat associated with oversized pumping systems. The SKF circulating oil lubrication unit provides the right amount of cool, clean oil directly to each bearing. The use of circulating oil lubrication may also reduce bearing vibration associated with the use of grease lubricant at higher speeds.

The SKF circulating oil lubrication units are available in three tank sizes; 30 liter (7.9 gallon), 50 liter (13.2 gallon), and 100 liter (26.4 gallon). Bearings with shaft sizes from 1 $\frac{1}{8}$ in. to 5 $\frac{1}{2}$ in. can be adequately lubricated with the SKF circulating oil lubrication system.

Features

- Large reservoirs cool oil quickly
- Large reservoirs de-aerate the oil properly
- Control options provide flexible installation and operation
- High pressure filtration up to 1,000 psi
- Easy to read level gauge
- Increased safety with back-up pump option for critical applications
- Non-tapered, threaded connections on the pressure side of the system help avoid leaks



30 liter tank – basic unit, no controls



50 liter tank – unit with controls

Product selection - important note

The following table is only a guide to assist in selecting the appropriate SKF circulating oil lubrication unit. Please consult SKF Application Engineering before purchasing and installing this product to ensure the proper unit has been selected based on all operating and application parameters.

Ordering details

Housing no.	Shaft sizes	Standard housings - drain size	SKF circulating oil lubrication unit*
SAF 507	1 ¹ / ₈ , 1 ³ / ₁₆ , 1 ¹ / ₄	1/8" NPT	VGRV MF2.....V511
SAF 509	1 ³ / ₈ , 1 ⁷ / ₁₆ , 1 ¹ / ₂	1/8" NPT	VGRV MF2.....V511
SAF 510	1 ⁵ / ₈ , 1 ¹¹ / ₁₆ , 1 ³ / ₄	1/8" NPT	VGRV MF2.....V511
SAF 511	1 ¹³ / ₁₆ , 1 ⁷ / ₈ , 1 ¹⁵ / ₁₆ , 2	1/8" NPT	VGRV MF2.....V511
SAF 513	2, 2 ¹ / ₁₆ , 2 ¹ / ₈ , 2 ³ / ₁₆ , 2 ¹ / ₄	1/8" NPT	VGRV MF5.....V517
SAF 515	2 ³ / ₈ , 2 ⁷ / ₁₆ , 2 ¹ / ₂	1/4" NPT	VGRV MF5.....V517
SAF 516	2 ⁹ / ₁₆ , 2 ⁵ / ₈ , 2 ¹¹ / ₁₆ , 2 ³ / ₄	3/8" NPT	VGRV MF5.....V517
SAF 517	2 ¹³ / ₁₆ , 2 ⁷ / ₈ , 2 ¹⁵ / ₁₆ , 3	3/8" NPT	VGRV MF5.....V517
SAF 518	3 ¹ / ₁₆ , 3 ¹ / ₈ , 3 ³ / ₁₆ , 3 ¹ / ₄	3/8" NPT	VGRV MF10.....V524
SAF 520	3 ⁵ / ₁₆ , 3 ³ / ₈ , 3 ⁷ / ₁₆ , 3 ¹ / ₂	3/8" NPT	VGRV MF10.....V524
SAF 522	3 ¹³ / ₁₆ , 3 ⁷ / ₈ , 3 ¹⁵ / ₁₆ , 4	3/8" NPT	VGRV MF10.....V524
SAF 524	4 ¹ / ₁₆ , 4 ¹ / ₈ , 4 ³ / ₁₆ , 4 ¹ / ₄	1/2" NPT	VGRV MF10.....V524
SAF 526	4 ⁵ / ₁₆ , 4 ³ / ₈ , 4 ⁷ / ₁₆ , 4 ¹ / ₂	1/2" NPT	VGRV MF210.....V532
SAF 528	4 ¹³ / ₁₆ , 4 ⁷ / ₈ , 4 ¹⁵ / ₁₆	3/4" NPT	VGRV MF210.....V532
SAF 530	5 ¹ / ₈ , 5 ³ / ₁₆ , 5 ¹ / ₄	3/4" NPT	VGRV MF210.....V532
SAF 532	5 ³ / ₈ , 5 ⁷ / ₁₆ , 5 ¹ / ₂	3/4" NPT	VGRV MF210.....V532

Ordering details

Housing no.	Shaft sizes	VZ 708, VZ 709 housings - drain size	SKF circulating oil lubrication unit*
SAF 507	1 ¹ / ₈ , 1 ³ / ₁₆ , 1 ¹ / ₄	3/8" NPT	VGRV MF5.....V517
SAF 509	1 ³ / ₈ , 1 ⁷ / ₁₆ , 1 ¹ / ₂	3/8" NPT	VGRV MF5.....V517
SAF 510	1 ⁵ / ₈ , 1 ¹¹ / ₁₆ , 1 ³ / ₄	3/8" NPT	VGRV MF5.....V517
SAF 511	1 ¹³ / ₁₆ , 1 ⁷ / ₈ , 1 ⁵ / ₁₆ , 2	3/8" NPT	VGRV MF5.....V517
SAF 513	2, 2 ¹ / ₁₆ , 2 ¹ / ₈ , 2 ³ / ₁₆ , 2 ¹ / ₄	3/8" NPT	VGRV MF10.....V524
SAF 515	2 ³ / ₈ , 2 ⁷ / ₁₆ , 2 ¹ / ₂	3/8" NPT	VGRV MF10.....V524
SAF 516	2 ⁹ / ₁₆ , 2 ⁵ / ₈ , 2 ¹¹ / ₁₆ , 2 ³ / ₄	3/4" NPT	VGRV MF10.....V524
SAF 517	2 ¹³ / ₁₆ , 2 ⁷ / ₈ , 2 ¹⁵ / ₁₆ , 3	3/4" NPT	VGRV MF10.....V524
SAF 518	3 ¹ / ₁₆ , 3 ¹ / ₈ , 3 ³ / ₁₆ , 3 ¹ / ₄	3/4" NPT	VGRV MF210.....V532
SAF 520	3 ⁵ / ₁₆ , 3 ³ / ₈ , 3 ⁷ / ₁₆ , 3 ¹ / ₂	3/4" NPT	VGRV MF210.....V532
SAF 522	3 ¹³ / ₁₆ , 3 ⁷ / ₈ , 3 ¹⁵ / ₁₆ , 4	3/4" NPT	VGRV MF210.....V532
SAF 524	4 ¹ / ₁₆ , 4 ¹ / ₈ , 4 ³ / ₁₆ , 4 ¹ / ₄	3/4" NPT	VGRV MF210.....V532
SAF 526	4 ⁵ / ₁₆ , 4 ³ / ₈ , 4 ⁷ / ₁₆ , 4 ¹ / ₂	3/4" NPT	VGRV MF210.....V532
SAF 528	4 ¹³ / ₁₆ , 4 ⁷ / ₈ , 4 ¹⁵ / ₁₆	1" NPT	Consult SKF Application Engineering
SAF 530	5 ¹ / ₈ , 5 ³ / ₁₆ , 5 ¹ / ₄	1" NPT	Consult SKF Application Engineering
SAF 532	5 ³ / ₈ , 5 ⁷ / ₁₆ , 5 ¹ / ₂	1" NPT	Consult SKF Application Engineering

* Based on oil drain rate using two drain holes.
Consult SKF Application Engineering for specific recommendations.

Ordering details

Part no.	Description	Specification
VGRV MF2-BW30-V511	Basic unit	0.24 liters / min flow rate
VGRV MF2X2-BW30-V511	Safety critical unit (back-up pump)	30 liter metal reservoir
VGRV MF2-BAW30-V511	Basic unit with controls	
VGRV MF2X2-BAW30-V511	Safety critical unit with controls	
VGRV MF5-BW50-V517	Basic unit	0.52 liters / min flow rate
VGRV MF5X2-BW50-V517	Safety critical unit (back-up pump)	50 liter metal reservoir
VGRV MF5-BAW50-V517	Basic unit with controls	
VGRV MF5X2-BAW50-V517	Safety critical unit with controls	
VGRV MF10-BW100-V524	Basic unit	1.1 liters / min flow rate
VGRV MF10X2-BW100-V524	Safety critical unit (back-up pump)	100 liter metal reservoir
VGRV MF10-BAW100-V524	Basic unit with controls	
VGRV MF10X2-BAW100-V524	Safety critical unit with controls	
VGRV MF210-BW100-V532	Basic unit	2.4 liters / min flow rate
VGRV MF210X2-BW100-V532	Safety critical unit (back-up pump)	100 liter metal reservoir
VGRV MF210-BAW100-V532	Basic unit with controls	
VGRV MF210X2-BAW100-V532	Safety critical unit with controls	

All units include

- Motor, 230/460 V, 60 Hz
- Single circuit gear pump unit with adjustable pressure regulating valve
- Sight glass with oil level
- Level switch
- Return port
- Pressure gauge
- 10 micron filter with electrical contamination indication
- Two-point flow meter
- Heater with integrated thermostat - 2 kW, 460 V, 60 Hz

Available options

- Oil over air heat exchanger
- Water cooled heat exchanger
- Stainless steel reservoir
- Explosion-proof components
- Stay dry desiccant tank breathers (see Accessories chapter)
- 24 V DC
- Temperature switches
- Pressure switches
- Higher capacity units

Single-circuit pumps

The pump units specified in this section are lubricant delivery pumps without pressure relief fixtures and are designed for continuous operation in circulating and hydrostatic lubrication systems.

These pump units may also be used for hydraulic tasks to the extent permitted by the pressure and viscosity ranges stated in the tables.

The drive is provided by a three-phase motor designed for a rated voltage of 230/400 V to DIN IEC 38.

The permissible pressure and delivery rates vary with the viscosity. When using oils with viscosities outside the indicated ranges (spindle oils and highly viscous oils), please consult SKF for further information.

Please note that even standard oils may become thin-bodied or highly viscous due to changes in temperature.

Ambient temperature maximum
+40° C (104° F)

Lubricant temperature 0° C to +80° C
(32° F to 176° F)



Gear pump unit



Pump unit with reservoir

Explanation of the hydraulic function

Referring to the diagrams below, oil is sucked in at S and flows through the pressure duct in direction P. The oil pressure closes valve V and opens valve E3 against spring tension. If air is entrained (due to low oil level in the reservoir), valve V remains open and bleeds the air or the air-intermixed oil into the return duct (see arrows marking the flow in directions R1 and R2 respectively). Valve C1 allows the excess-pressure oil to flow into the return duct.

Explanation of the structural differences

With type MF, the short screw plug D2 leaves flanged port R2 open – contrary to D1 with type M – and a plug seals external port R1. Flanged port R2 of the return duct discharges directly into the reservoir without any threaded connections (see Fig. 2 and 3).

Type MF units for flange-mounting on oil reservoir

Use a special sealed pump for horizontal flange-mounting of the unit beneath oil level

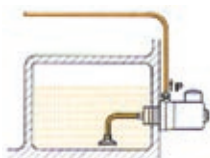

Figure 1

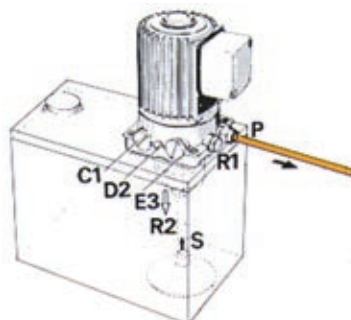

Figure 2

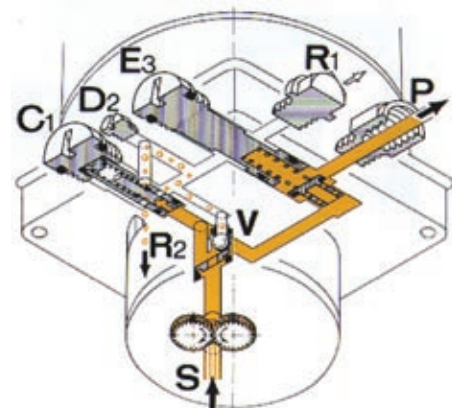

Figure 3

Ordering details - single circuit gear pump units

For flange-mounting on oil reservoir Order no.	Output ¹⁾ [l/min]	Maximum back pressure [bars]	Permissible operating viscosity range [mm ² /s]	Suction head (with open pressure line) [mm]	Three-phase motor		Rated current at 50Hz, 230/400 V [A]	Suction port S thread d1
					Rated output [kW]	Rated speed [rpm]		
VGBA MF2	0.24	60	140 - 1000	500	0.13	3300	0.65 / 0.37	M14 x 1.5
VGBA MF5	0.6	27	20 - 1000	500	0.13	3300	0.65 / 0.37	M14 x 1.5
VGBA MF10	1.2	27	20 - 1000	500	0.13	3300	0.65 / 0.37	M14 x 1.5
VGBA MF210	2.4	27	20 - 1000	500	0.13	3300	0.65 / 0.37	M14 x 1.5

1) Output based on an operating viscosity of 140 mm²/s at a back pressure of p = 5 bars

2) Also see leaflet 1-1202-US page 4: Multirange voltage motors.

Single-circuit units complete with reservoir see page 61.

Standard dimensions of reservoirs starting at 30 liters (dimensions in mm)

Reservoir capacity [liters]	Height			Width		Depth	Center distance	Center distance	Hole
	h	h2	h3	b1	d1	d1	b2	d2	Ø
30	375	245	237	510	320	320	430	240	14
50	480	310	300	570	350	350	490	270	14
100	510	340	326	710	500	500	630	420	14

30 and 50 liter reservoirs available, also without legs, for wall-mounting.

- 1 = Oil filler cap
- 2 = Oil strainer
- 3 = Float switch
- 4 = Gear or oil strainer gerotor pump unit
- 6 = Oil level indicator
- 7 = Oil drain plug

Reservoir and cover: hammered enamel finish

The complete reservoir units are also available in conformity with the regulations of the automobile industry.

DIN and special reservoirs on request.

Example: 50 liter reservoir

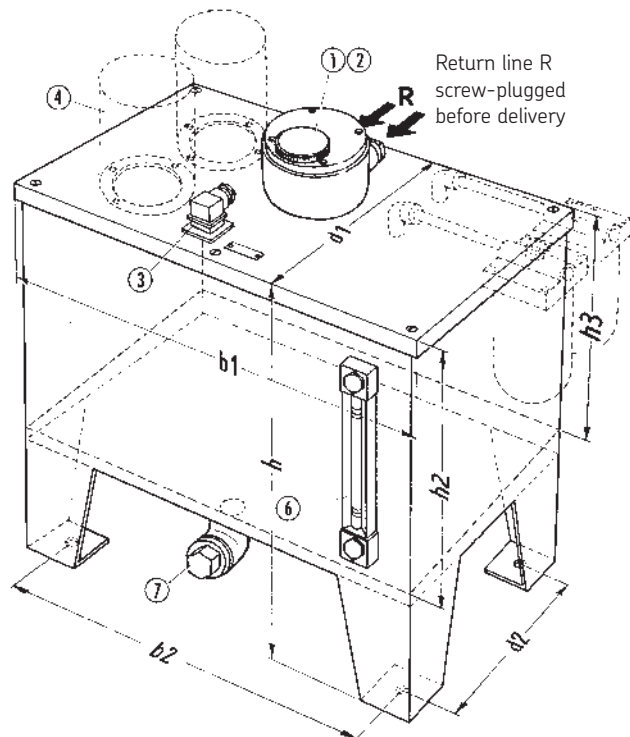

Safeflow™ oil flowmeters

Safeflow™ oil flowmeters are used for controlling and measuring the flow rate of lubricants in paper machine oil lubrication systems.

The base is made of durable aluminum. The flow tube is made of glass, so high temperatures and the use of synthetic oils should present no problems.

The Safeflow flowmeter has a straight glass flow tube with an internal calibrated cone extending along its vertical axis. The float is cylindrical, its O.D. being the same dimensions as the I.D. of the flow tube, with an annular opening through its center along its vertical axis. In operation, the calibrated cone extends through the annular opening in the float, creating the variable orifice needed for measurement as the float moves with flow changes. Because the oil flows through the float, rather than around it as in ordinary flowmeters, the float is always clearly visible. A white Teflon ring on the float marks the reading point and wipes the inside wall of the glass tube.

The flowmeter can be field calibrated so that when the desired oil flow is properly adjusted, the white ring will line up with a predetermined mark. This makes it easy to monitor banks of flowmeters with different required flows because all floats will be at the same level and it will not be necessary to remember the correct flow value for each bearing.



Flow change alarm system

The oil flow through each Safeflow flowmeter can be remotely and continuously monitored. The alarm system consists of one alarm sensor for each flow tube and one monitoring unit for up to ten alarm sensors. The alarm sensor is an inductive proximity

switch, which identifies the location of a metal float in the tube. The monitoring unit contains the terminals and the power supply for ten sensors. The system transmits either a single alarm from each bank of meters or a separate signal from each flow tube. The alarm delay can also be selected to avoid false alarms.

Ordering details

For use with . . .	Basic unit	Basic unit with controls	Safety critical unit
30 fan unit tank capacity (liters)	SF05A-02UX	SF05A-02UX	SF05A-02UA-BSS
50 fan unit tank capacity (liters)	SF10A-02UX	SF10A-02UX	SF10A-02UA-BSS
100 fan unit tank capacity (liters)	SF10A-02UX	SF10A-02UX	SF10A-02UA-BSS
Flow rate	SF05A	SF10A	
100cSt (460 SSU)	0.1 - 0.7 liters / min 0.2 - 1.5 pints / min	0.1 - 3.0 liters / min 0.2 - 6.3 pints / min	
220cSt (1000 SSU)	0.04 - 0.35 liters / min 0.08 - 0.74 pints / min	0.1 - 1.7 liters / min 0.2 - 3.6 pints / min	

Note: When ordering, use SKF prefix designation VGDC. Example: VGDC SF10A-02UA-BSS

Level switches

For oil, hydraulic and fluid reservoirs

Level switches are used to monitor the level of fluids in unpressurized reservoirs. Various versions are available to meet the different requirements necessary for the monitoring of fluid levels.

- Switches with one switching point (VGDA WS32-...), e.g. ones used to monitor the minimum level of fluid in a reservoir.
- Switches with two switching points (VGDA WS35-...), likewise used to monitor the minimum level of fluid, emit an advance warning before a critical level is reached and without having to shut down the machine. Before the second switching point is reached, there is still enough oil in the reservoir for a shift to be completed without having to stop the machine or interrupt work.
- Switches with two switching points (VGDA WS33-...), e.g. for a minimum and maximum level of fluid in the reservoir, automatic topping up of the reservoir being terminated, for example, before the maximum level is reached.

Further level switches, e.g. for other fluids like NLGI grades 000 and 00 grease, are available on request (capacitive proximity switches).

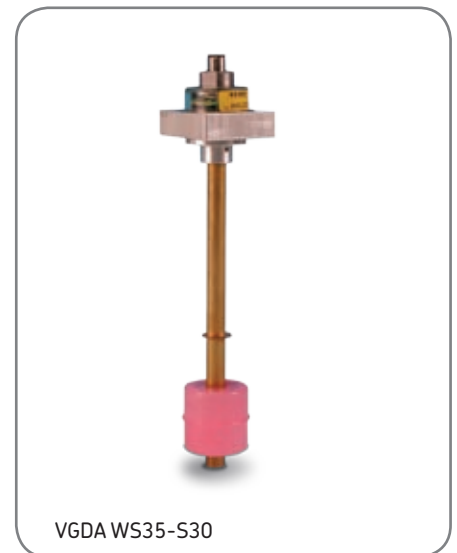

Tips for the use of level switches

Pay attention to the viscosity of oil!

Only use oils and other fluids with a maximum effective viscosity of 1,500 mm²/s.

Fluids with an effective viscosity greater than 1,500 mm²/s can lead to indication failures due to the increase in shear forces between the float and contact tube.

Ordering details

Group	Contact function / type of contact	Plug	Number of switching points
VGDA WS32-2	Minimum level / 1 changeover contact	Connector plug DIN EN 175301-803-A	1 switching point
VGDA WS33-2	Maximum level / 1 NO type Maximum level / 1 NC type	Connector plug DIN EN 175301-803-A	2 switching points
VGDA WS35-2	Advance warning / 1 NO type Minimum level / 1 NC type	Connector plug DIN EN 175301-803-A	2 switching points with fixed spacing approximately 25 mm

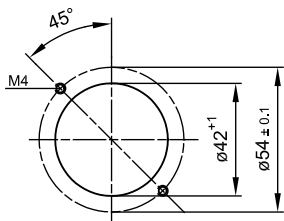
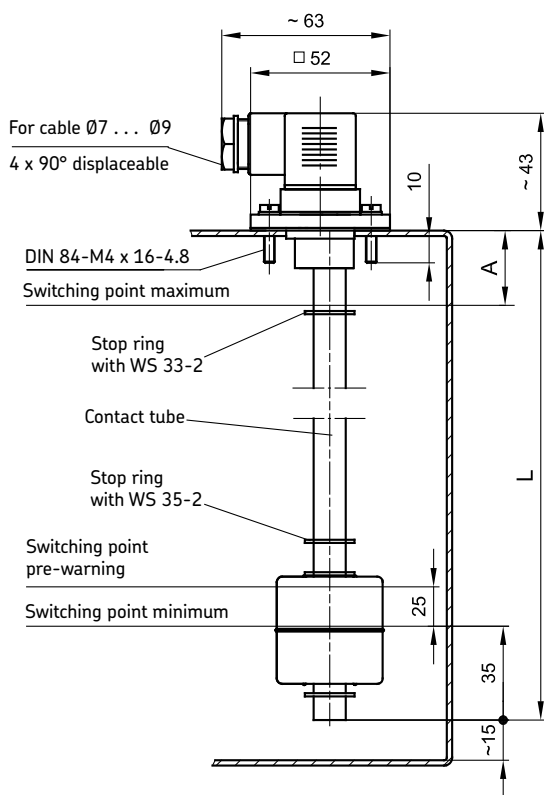

Drilling template for reservoir cover

VGDA WS32-2 / WS33-2 / WS35-2

When the level of fluid drops, a toric magnet built into the float actuates the reed contact cast into the contact tube. If necessary, the contact tube can be used to trigger a signal that calls for the reservoir to be topped off. The switching point for the minimum lubricant level is always 35 mm above the end of the contact tube.

The level switch WS33-... has an upper switching point for the maximum level in addition to the lower one. Control of automatic filling and emptying is possible with this model.

The level switch WS35-... has two contacts in the lower area that respond one after the other. The first switching point issues the advance warning. The second switching point can, after the float travels roughly 25 mm, break a connected command link and thus shut down a machine. The advance warning remains in effect.

**VGDA WS32-2
for minimum level**

Types of contact

1 changeover – for minimum level
(magnetically actuated reed contact)

Function

After the level of fluid drops to a
minimum level, contact 1 – 2 opens
and contact 1 – 3 closes.

**VGDA WS33-2
for minimum level and
maximum level**

Types of contact

1 NO type – for maximum level
1 NC type – for minimum level
(magnetically actuated reed contacts)

Function

Contact 1 – 3 closes after the fluid
rises to a maximum level;
Contact 1 – 2 opens after the fluid
drops to a minimum level.

**VGDA WS35-2
for minimum level with
pre-warning**

Types of contact

1 NO type – pre-warning
1 NC type – for minimum level
(magnetically actuated reed contacts)

Function

After the level of fluid drops to 25
mm above the minimum filling level,
contact 1 – 3 closes; if the level of fluid
continues to drop to the min. level,
contact 1 – 2 opens.

Ordering example

When ordering, please also indicate the desired lengths A (minimum 50 mm at VGDA WS33...) and L (at VGDA WS32... minimum 100 mm; at VGDA WS33... and VGDA WS35... minimum 120 mm) in addition. Please observe preferred lengths. Preferred lengths A = 50, 65 and 100 mm

Ordering examples:

VGDA WS32-2 with order length L = 150 mm:

Order no.: VGDA WS32-2-150

VGDA WS33-2 with order length A = 50 mm, L = 200 mm:

Order no.: VGDA WS33-2-50-200

Preferred lengths for order length L:

100, 125, 150, 200, 230, 250, 290, 315, 350, 400, 450, 500 mm

Lubrication systems for tabletop chain

'Dry lubrication' systems for filling and packaging conveyors in the food industry

Applications

The 'dry lubrication' systems eliminates the use of water-soluble lubricants. Using special lubricants, these systems have been developed to lubricate belt conveyor surfaces, as well as the conveyor guides, for the transport of products on bottling and packaging conveyors.

A metered volume of lubricant is applied to the belt surface by means of coating plates that contact the conveyor chain at the same time lubricant is directly injected into the conveyor guide with the same lubrication unit. The metered volume of lubricant is independent of any possible lubricant viscosity variation, the line length or the lube point number.

Considering the large diversity of conveyors, several system types have been designed in order to suit every kind of application.

'Dry lubrication' systems are used on filling lines for beverage cartons, plastic bottles, and so on, in the following segments of the food industry:

- Milk and dairy plants
- Fruit juice, sauce and soup production
- Bottled water production
- Beverages (soda, beer, etc.)

And in many other fields such as:

- Cleaning products
- Cosmetics
- Pharmaceuticals



Features

- Better sliding of the products
- Reduced chain wear
- Safety and cleanliness
- Dry environment, no water
- Less metal corrosion
- No deterioration of the conveyed products in the holding area
- No friction noise or "stick-slip" effect
- No bacterial growth
- Complies with environmental standards
- Approved for use in food applications

Problems on line conveyors

Due to the speed difference between the filling machine and the packaging machine, or the failure of one of them, products slow down, fall and collect on the belt conveyor at the end of the line.

At the same time guides are supporting the conveyor belt where there is continuous friction.

If the friction between the belt and the product is too high (without lubrication), package bottoms can be damaged, especially cartons. The belt then needs more power for moving, resulting in belt damage.

A lubrication system helps to keep a constant and sufficient friction coefficient. It can be adapted to any production line (conveyor belt type, carried products).

- Too much friction (insufficient sliding) results in:
 - Possible deterioration of the products (especially cartons)
 - More power consumption for the belt motion (engine over-current extreme tension of the belt)
 - Possible falling of the products when changing direction
 - More wear on the belt surface and guides
- Where there is not enough friction, products slide too much and it is hard to carry them properly (they slow down or stop moving completely)

Disadvantages of the water + soap solution

Currently, some lubrication systems are based on a spraying network of water + soap. With these systems, it is not possible to precisely meter the quantity of lubricant sprayed on the belt (it is often higher than the real amount needed), and the use of water causes many problems:

- Bacteriological and organic growth
- High costs due to excessive water consumption and effluent treatment
- Foaming
- Corrosion
- Slippery floors
- Damaged packages

Dry lubrication

Dry lubrication systems have been especially designed for the lubrication of conveyor surfaces and guides with special lubricant.

These systems replace classic wet lubrication systems due to the high performance of the lubricant: a PTFE based oil suitable for the food industry. When correctly metered, it leaves a dry sliding coat on the belt surface and/or its guides.

The aim of the dry lubrication system is to deliver automatically and precisely the right quantity at the right friction point (belt surface or guides) from a central unit, which can feed many lubrication points.

Lubricant application principle

• Lubrication of the conveyor belt surface

Very small metered quantities of oil are delivered intermittently by a piston metering system into a number of coating plates that contact the conveyor chain.

The coating plates deliver an oil film on the chain as long as the unit is actuated.

• Lubrication of the guides

The same metering system, connected to the same central unit, is used to directly inject a metered quantity of lubricant through a tube and connector fitted on the guides.

If you would like more information on SKF tabletop chain systems, contact SKF or your local SKF distributor.

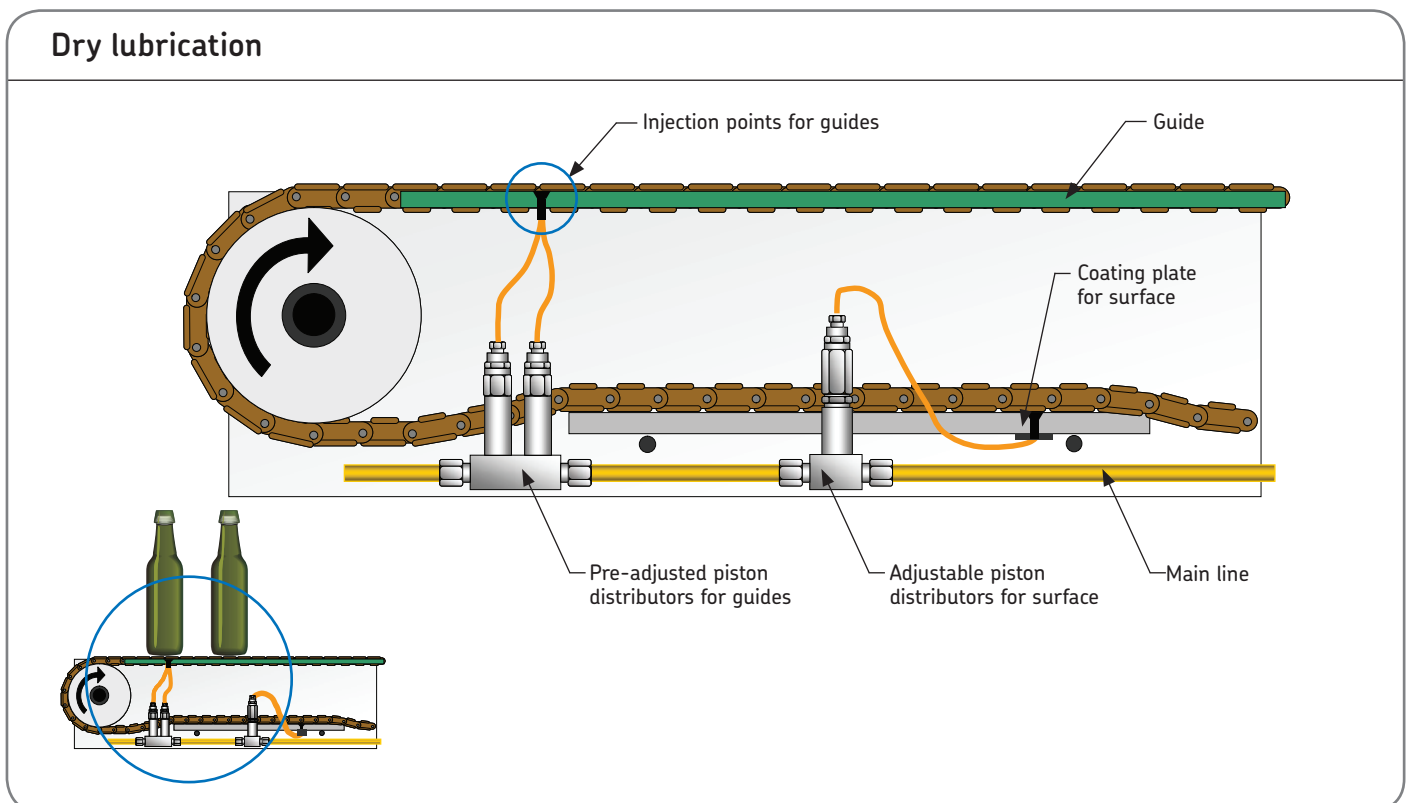

Compact units for oil

Group MKU – 0.1, 0.2 or 0.5 l / min

These MKU compact units were developed to supply intermittently operated single-line central lubrication systems with lubricant. The basic model contains a gear pump with drive motor as well as the set of valves required for pressure relief and limitation (safety valve). The lubricant reservoir material is metal or plastic.

The units are controlled depending on their design:

- by hand
(unit with a pushbutton DK)
- by an external control system
- by a built-in electronic control and monitoring unit, timer or counter with adjustable interval and monitoring time
- by a built-in electronic control unit with adjustable interval time and fixed pump running time.

The control and monitoring unit is either a timer for time-dependent control or a counter for load-dependent control.

Design features

- Preliminary lubrication (lubrication after the supply voltage is turned on)
- Pump delay time
- Pressure dependent cut-off
- Monitoring of pressure build-up
- Monitoring of pump running time

Possible monitoring elements

- Pressure switch (DS) monitors the automatic pressure build-up
- Level indicator (WS)
- Pressure gauge (MA) displays the pressure response in the main line
- Monitoring contact turns off machine if pressure fails to build up
- Indicator light, green shows that pump is running
- Indicator light, red indicates a fault if pressure fails to build up or if there is a low level of lubricant in the reservoir (only with built-in level indicator)



MKU2-KW3-22003



MKU2-KW6-22003



MKU2-BW3-22003

Ordering details

Order no.	Delivery rate [l/min]	Reservoir capacity [l]	Reservoir material *	Components			
				DK	DS	WS	MA
VGBB MKU2-KW3-22003	0.2	3	K	•	•	•	•
VGBB MKU2-KW3-22013	0.2	3	K	•	•	•	•
VGBB MKU2-KW6-22003	0.2	6	K	•	•	•	•
VGBB MKU5-KW6-22003	0.5	6	K	•	•	•	•
VGBB MKU2-BW3-22003	0.2	3	B	•	•	•	•
VGBB MKU2-BW3-22013	0.2	3	B	•	•	•	•

* Reservoir material: K = plastic B = metal

• = components contained in the unit

DK = Pushbutton / DS = pressure switch / WS = level indicator / MA = pressure gauge

Piston distributors



Group 340 (0.1 - 0.6 cm³)



Group 350 (0.1 - 0.6 cm³)



Group 390 (0.2 - 1.5 cm³)

For single-line total-loss lubrication systems

Piston distributors meter out and distribute the oil delivered by an intermittently actuated pump.

The quantities of oil for the individual lube points are determined by exchangeable metering nipples. The metered amount is indicated on the individual nipples. The amount needed

to cover the total oil demand can then be further regulated via the lubricating frequency.

To meet the required quantities and comply with spatial constraints, it is possible to choose among four distributor groups that differ in terms of their metering ranges and sizes. The functional principle of the groups is the same but there are differences in design.

Different distributor groups can be used in one installation.

Please note: Seal material: NBR. In general, the operating conditions specified for the respective pump units will also apply to the distributors.

Limit values for the distributors:
 Temperature range: 0° C to + 80° C (32° F to 176° F)
 Effective oil viscosity: 5 to 2,500 mm²/s

Function

1. The amount of oil intended for the lube point is stored in front of the piston in the distributor.
2. When the central lubrication pump starts delivering oil, the piston moves and the oil in front of it is fed to the lube point at a main line pressure of 12-45 bars.
3. After the pressure is relieved (≤ 1 bar) in the main line, the distributor's piston returns to its initial position and once again lets a certain quantity of oil flow into the space in front of it.

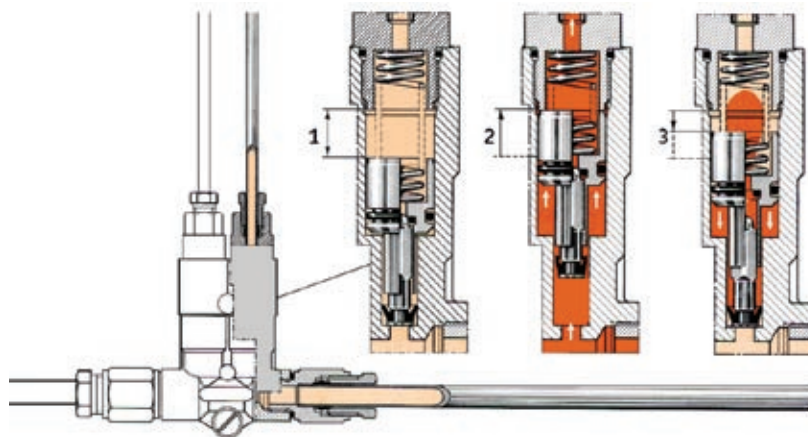

Piston distributors, group 340

0.01 - 0.16 cm³ (for oil)



Piston distributors (available only with metering nipples installed)

Order no.	Number of lube points
VGAA 342-4	2
VGAA 343-4	3
VGAA 345-4	5

Metering nipple with O-ring, exchangeable

Order no.	Related metered quantity [cm ³]	Order key	Marking on the metering nipple
Metering nipple not exchangeable	0.01	1	1
Metering nipple not exchangeable	0.02	6	2
995-994-103	0.03	2	3
995-994-106	0.06	3	6
995-994-110	0.10	4	10
995-994-116	0.16	5	16

To order:

The order no. has 9 places.

To complete the order no., supplement it with the order key to specify the desired metered quantities.

Ordering example:

Piston distributor, 5-port type, 345-4

metered with (from left to right) 0.03 - 0.10 - 0.10 - 0.16 - 0.06 cm³

Order key: 2 4 4 5 3

Order no.: 345-424-453

Group 340-... distributors are intended for direct connection to a main line with a diameter of 6 mm (double tapered sleeve and socket union)

Please note:

The piston distributors comprising Groups 340, 350 and 390 are only supplied complete with metering nipples.

Possible tubing connection: M8 x 1 ports tapped for solderless Ø4 tube connection.

Piston distributors, group 350

0.1 - 0.6 ccm (for oil)



Piston distributors (available only with metering nipples installed)

Order no.	Number of lube points
VGAA 351-0	1
VGAA 352-0	2
VGAA 353-0	3
VGAV 355-0	5

Metering nipple with O-ring, exchangeable

Order no.	Related metered quantity [cm ³]	Order key	Marking on the metering nipple
352-010-K	0.1	4	0.1
352-020-K	0.2	5	0.2
352-040-K	0.4	6	0.4
352-060-K	0.6	7	0.6

Ordering example:

Piston distributor, 3-port type, 353-0 00 metered with (from left to right) 0.1 - 0.4 - 0.2 cm³

Order key: 4 6 5

Order no.: 353-046-500

Piston distributors, group 390

0.2 - 1.5 cm³ (for oil)



Piston distributors (available only with metering nipples installed)

Order no.	Number of lube points
VGAA 391-0	1
VGAA 392-0	2
VGAA 393-0	3

Metering nipple with O-ring, exchangeable

Order no.	Related metered quantity [cm ³]	Order key	Marking on the metering nipple
391-020-K	0.2	5	0.2
391-040-K	0.4	6	0.4
391-060-K	0.6	7	0.6
391-100-K	1.0	8	1.0
391-150-K	1.5	9	1.5

Order example:

Piston distributor, 3-port type, 393-0 . . - . 00
 metered with (from left to right) 1.5 – 1.0 – 0.4 cm³

Order key: 9 8 6

Order no.: 393-098-600

Example of group 350 distributors:

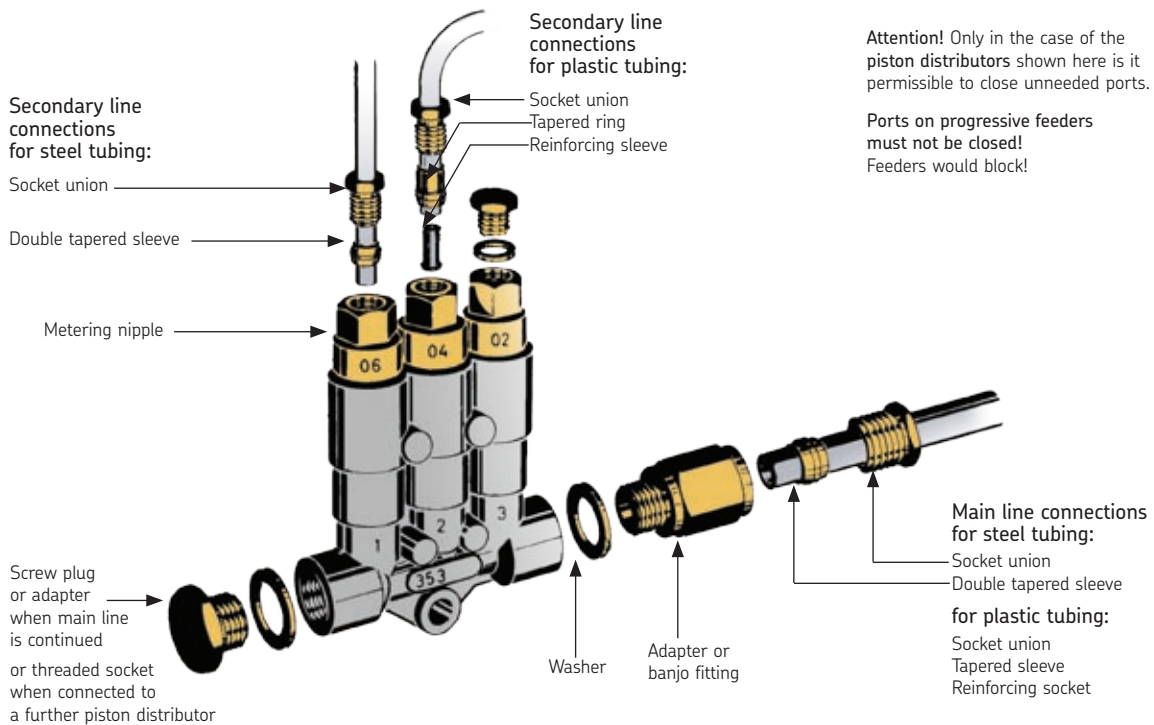

Flow monitors and sensors for oil

For intermittent and circulating centralized lubrication systems

Flow monitors / sensors have the task of monitoring the flow of oil from the pump or a piston distributor element to the lube point. Flow monitors with various designs are used for this job.

Flow monitors / sensors monitor the flow of oil from a piston distributor to the lube point, the piston distributor metering out a small amount of oil for only a short period of time. Depending on the type, flow monitors / sensors can monitor oil quantities ranging from 10 mm³ all the way to 1,500 mm³ per lubricant pulse.

A further task involves monitoring a continuous flow of oil from a pump through a lubrication system. These flow monitors are designed for a



throughput ranging from 50 cm³ to 14,000 cm³.

The following issues should be considered when selecting an appropriate flow monitor:

- Intermittent or continuous operation
- Oil quantity to be monitored
- Effective viscosity of the lubricant
- System pressure



Ordering details

Order no.	Designation	Metered quantity, flow rate	Application	Port A	Port B ¹⁾	
VGDC 171-210-051	Flow monitor	50 - 100 cm ³ / min	Circulating central lubrication systems	M10 x 1	M18 x 1.5	
VGDC 171-210-052		100 - 200 cm ³ / min		M10 x 1	M18 x 1.5	
VGDC 171-210-053		200 - 500 cm ³ / min		M10 x 1	M18 x 1.5	
VGDC 171-210-054		500 - 800 cm ³ / min		M10 x 1	M18 x 1.5	
VGDC 171-210-055		800 - 1800 cm ³ / min		M10 x 1	M18 x 1.5	
VGDC 171-210-061	Flow monitor	1.6 - 2.5 liters / min	Circulating central lubrication systems	M18 x 1.5	M18 x 1.5	
VGDC 171-210-062		2.3 - 4.0 liters / min		M18 x 1.5	M18 x 1.5	
VGDC 171-210-063		3.6 - 6.0 liters / min		M18 x 1.5	M18 x 1.5	
VGDC 171-210-064		5.5 - 10.0 liters / min		M18 x 1.5	M18 x 1.5	
VGDC 171-210-065		8.0 - 14.0 liters / min		M18 x 1.5	M18 x 1.5	
VGDC GS300	Flow sensor	10 - 600 mm ³ / pulse	Intermittent central lubrication systems ²⁾			
VGDC GS304N		10 - 600 mm ³ / pulse				Intermittent central lubrication systems ²⁾
VGDC GS304P		10 - 600 mm ³ / pulse				
VGDC GS4011-S20	Oil-streak sensor	120 -600 mm ³ / h	Oil + air central lubrication systems			
VGDC GS6011-S20		120 -600 mm ³ / h				
VGDC GS4011-S50		60 -120 mm ³ / h				
VGDC GS6011-S50		60 -120 mm ³ / h				

1) DIN 2353 / ISO 8434-1. Only permissible for the use of preassembled fittings. We recommend use of a preassembled EO-2 screw union. (Example: GA21 ...23/GA30).
 2) e.g. with piston distributors, metering elements, injection oilers

Flow monitors for the monitoring of a continuous flow of oil (circulating lubrication system)



Ordering details

Order no.	Flow rate application range (cm ³ / min)	Order no.	Flow rate application range (liter / min)
VGDC 171-210-051	50 - 100	VGDC 171-210-061	1.6 - 2.5
VGDC 171-210-052	100 - 200	VGDC 171-210-062	2.3 - 4
VGDC 171-210-053	200 - 500	VGDC 171-210-063	3.6 - 6
VGDC 171-210-054	500 - 800	VGDC 171-210-064	5.5 - 10
VGDC 171-210-055	800 - 1800	VGDC 171-210-065	8.0 - 14

GS300, GS304N, GS304P

Flow sensors for monitoring of lubricant feed right at the lube point

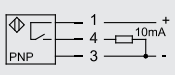
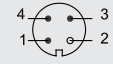
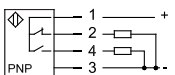
Ordering details

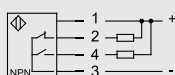
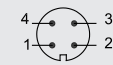
Order no.	Switching function	Electrical connection
VGDC GS300 	Pin 1 (BN - brown): +24 V Pin 3 (BU - blue): 0V Pin 4 (BK - black): PNP / NO - closes in event of flow	
VGDC GS304P 	Pin 1 (BN - brown): +24 V Pin 2 (WH - white): PNP / NC - opens in event of flow Pin 3 (BU - blue): 0 V Pin 4 (BK - black): PNP / NO - closes in event of flow	
VGDC GS304N 	Pin 1 (BN - brown): +24 V Pin 2 (WH - white): NPN / NC - opens in event of flow Pin 3 (BU - blue): 0 V Pin 4 (BK - black): NPN / NO - closes in event of flow	

GS4011-S..., GS6011-S...

The oil-streak sensors monitor the continuity of the oil flow in oil + air lubrication

Oil + air centralized lubrication systems are used in the case of minimal-quantity and oil + air lubrication systems, e.g. to supply high-speed rolling bearings in tool spindles. The bearings are supplied with extremely small quantities of lubricant for such applications. To achieve such small quantities of oil per unit of time, what was originally a relatively large drop of oil is broken down by a current of air on its way from the metering point to the bearing. The oil to be delivered is fed in the line to the bearing as a thin flow of lubricant along the wall.

Monitoring

So far, only the metered quantity of oil from the metering element has been checked upstream of the oil and air mixing point. The oil-streak sensor makes it possible to monitor the transport of a fine current of oil along

the secondary line's wall downstream of the oil and air mixing point. The closer the sensor is located to the lube point, the more reliable the system monitoring.

Ordering details

Order no.	Plastic tubing Ø D	Flow rate [mm ³ /h]
VGDC GS4011-S20	4	120 - 600
VGDC GS4011-S50	4	60 - 120
VGDC GS6011-S20	6	120 - 600
VGDC GS6011-S50	6	60 - 120

Technical data

LAGD 1000 (page 53)

Designation	LAGD 1000/B	LAGD 1000/DC	LAGD 1000/AC
Maximum operating pressure	150 bars (2 175 psi)	150 bars (2 175 psi)	150 bars (2 175 psi)
Permissible operating temperature	-10° to 60° C (14° to 140° F)	-25° to 75° C (-13° to 167° F)	-25° to 60° C (-13° to 140° F)
Number of outlets	6 to 12	10 to 20	10 to 20
Maximum length of pipes	6 m (19.7 ft.)	6 m (19.7 ft.)	6 m (19.7 ft.)
Tubing	6 x 1.25 mm (0.05 in)	6 x 1.25 mm (0.05 in)	6 x 1.25 mm (0.05 in)
Output of pump element	1 cm ³ /min (0.061 in ³ /min)	2 cm ³ /min (0.122 in ³ /min)	2 cm ³ /min (0.122 in ³ /min)
Reservoir capacity	1 liter (33.8 fl. oz.)	1 liter (33.8 fl. oz.)	1 liter (33.8 fl. oz.)
Greases	Up to NLGI grade 2 Flow pressure < 300 mbar	Up to NLGI grade 2 Flow pressure < 700 mbar	Up to NLGI grade 2 Flow pressure < 700 mbar
Weight	5.8 kg (12.8 lbs.)	3.7 kg (8.2 lbs.)	4.8 kg (10.6 lbs.)
System of protection	IP65	IP65	IP65
Electrical specifications			
Power connection	n/a	DIN EN 175 301-803, Plug supplied	DIN EN 175 301-803, Plug supplied
Rated voltage	18V	24V DC	110 - 240V 50/60 Hz
Power consumption	16 Ah	-	-
Battery type	alkaline	-	-
Type power input at 20 °C (68 °F) and max. operating pressure		0.5 A	1.3A / 110V 0.4A / 230V
Battery pack life	12 months or 1 lubricator filling (whichever comes first) when installed by end of the battery pack expiration date.		

Mini-pump units group (page 54)

KFA/KFAS

Operating voltage	12 V DC / 24 V DC (please indicate when ordering) (230 V AC design is a special order)
Mode/on time	S3 / 20% - 50 minutes Pay attention to interval and contact time when setting! Maximum runtime 10 minutes, interval time = 4 x runtime
Maximum back pressure	300 bars
Permissible operating temperature	-25° to + 75° C (-13° to 167° F)
Reservoir capacity	1 liter
DIN 40050 enclosure, T9	IP 6K9K
Maximum number of outlets	2
Weight (filled with grease)	Approximately 3.8 kg
Lubricant	Grease up to NLGI grade 2 Flow pressure up to maximum 700 mbars

Piston pump, KFAS1-B series (page 55)

Operating voltage	18 V DC	Control unit	
Maximum operating temperature	150 bars	Adjustable parameters	Interval time Contact time Acoustic alarm Cycle switch
Delivery rate, outlet port 1	1 cm ³ /min (standard KFA1.U1)		
Delivery rate, outlet port 2	without (standard) ¹⁾	Retrievable parameters	Operating hours Fault hours Contact time Software
Operating temperature	-10° to + 60° C (14° to 140° F)		
Reservoir capacity	1 liter	Fault signals	Reservoir empty (filling level) Battery dead (battery status) Temperature ≤ -10° C (14° F) Malfunction (optional) (With optional cycle switch)
Lubricant	grease up to NLGI grade 2 (NLGI grade 3 on request) with EP additives maximum flow pressure 200 mbars		
Type of enclosure	IP 65		

1) Optionally expandable for second lube circuit
pump element KFA1.U1 - delivery rate 1 cm³/min
pump element KFA1.U2 - delivery rate 0.75 cm³/min
pump element KFA1.U3 - delivery rate 0.5 cm³/min

Level switches (page 67)

Switching element	Reed switch	Mounting position	
Type of enclosure	IP 65	WS32-.../WS33-.../WS35-... WS68	Vertical Horizontal
Normen	EN 60947-5-1	Material	
Temperature range	-10° to + 60° C (14° to 140° F)	WS32-.../WS33-.../WS35-... Flange Contact tube Seals Float	Al CuZn NBR PP
	Suitable for fluids with a maximum eff. viscosity of 1500 mm/s		
1) Protective measures to be taken for operation. "Functional Extra-Low Voltage with Protective Separation" (FELV) Standard EN 60204-1 / IEC 60204-1 HD 384.4.41 (DIN VDE 0100-410) / IEC 60364-4-41			

Flow monitors (page 76)

Operating viscosity	20 - 1000 mm ² /s	Type of enclosure	IP 65
Actuating pressure	Minimum 4 bars ¹⁾ , maximum 25 bars	Mounting position	Any
Electric switching	Changeover 250 V AC, 0.5 A	Materials	
Permanent operating temperature	+ 5° to + 80° C (41° to 176° F)	Housing Seals	Die-cast zinc, polyamide NBR (FPM version on request)
1) If the flow monitors are equipped with metering restrictors, at least 6 bars are required in the feed line.			

GS300, GS304N, GS304P series (page 76)

Suitable metered quantities from	0.01 to 0.6 cm ³ / pulse	Electrical data	
Clock frequency	Maximum 4 pulse / min	Rated voltage U_N	24 V DC
Lubricant	Oil (10 to 2000 mm ² / s)	Residual ripple	10%
Maximum operating pressure	Maximum 40 bars	Working range U_A	18 to 30 V DC
Installation	Directly upstream of lube point	Maximum power consumption I_E	Maximum 25 mA
Vibration resistance	20 g (DIN/IEC 68-2-27, 10-2000 Hz)	Pulse output	3s
Impact resistance	50 g (DIN/IEC 68-2-27, 11 ms)	Load current I_A for GS300 for GS304	Maximum 10 mA Maximum 500 mA per output
		Output protection	Short-circuit protection
		Built-in plug	Circular connector with M12 x 1 screw plug

GS4011-S..., GS6011-S... series (page 76)

Fluid	Oil + air	Electrical data	
Maximum operating pressure	10 bars	Rated voltage U_N	24 V DC ¹⁾
Operating temperature	0 bis + 60° C	Operating range U_B	20 bis 30.5 V DC
Mounting position	Any	Maximum power consumption I_E	40 mA
Accessories	Connection cable with straight cable Socket, 4 - pole type, length 5 m, Order no. DS-E.U2 Socket, 90° angled, Order no. 179-990-372	Type of enclosure	IP 54
		Outputs	PNP type Closes when oil streaks detected, Opens when there are none
1) Protective measures to be taken for operation in conformity with "Functional Extra-Low Voltage with Safety Separation" (PELV = Protective Extra-Low Voltage)			
		Color-coding with standard sensor cables	
		Brown (BN)	+24 V
		Blue (BU)	GND
		Black (BK)	Make contact
		White (WH)	Break contact

Accessories

Disposable gloves TMBA G11D	82
Grease pumps	82
Multi-outlets drum pump GSE	84
PTEX extruder pumps	86
Lubrication accessory sets	88
Connection systems	89
Fittings and accessories	92
Electric plug-and-socket connectors	94
Stay-dry tank breathers	96
OilCheck monitor TMEH 1	98
Handheld viscometer TMVM 1	98
Portable filter cart	99
Oil Safe®	100
Technical data	102



Disposable Grease-resistant Gloves TMBA G11D

Skin protection when handling grease

Specially designed to protect the skin when working with SKF bearing grease. The gloves are packed in a handy box containing 50 pairs.

- Non-powdered nitrile rubber gloves
- Close fitting for precision wear
- Excellent resistance against bearing greases
- Non-allergic



Grease Filler Pumps LAGF series

High quantity grease packer

SKF filler pumps are suitable for filling grease guns. Especially designed for use on grease gun 1077600 and LAGH 400. Tested and approved for SKF greases. Easy to install and ready for use. Available for standard SKF 18 and 50 kg (39 and 110 lb) drums.

- Quick filling: low pressure allows higher stroke volume
- Easy to install: all necessary items are included
- Reliable: tested and approved for all SKF greases
- Can be used in combination with SKF bearing packer VKN 550



Ordering details

Designation	Description
LAGF 18	Grease filler pump for 18 kg drums
LAGF 50	Grease filler pump for 50 kg drums



Grease Pumps LAGG series

Meeting all your grease lubricator needs

Full range of manual and air-operated grease pumps are designed to empty standard 18, 50 or 180 kg (39, 110 or 400 lb) grease drums. Can be connected directly on the greasing points, also suitable for centralized

lubricating grease systems.

SKF grease pumps have a maximum pressure of 40 and 42 MPa (5,800 and 6,090 psi) respectively. Pumps are tested and approved for SKF greases. Easy to install and ready for use since pumps are supplied with all necessary items including 3,500 mm (137.8 in) of tubing.

- Full range; pumps available for 18, 50 or 180 kg (39,110 or 400 lb) drums
- High pressure; maximum of 42 MPa (6,090 psi)
- Easy to install; all necessary items as well as 3,500 mm (137.8 in) of tubing are included
- Reliable; tested and approved for SKF greases
- Can be used in combination with SKF bearing packer VKN 550

Ordering details

Designation	Description
LAGG 18M	Grease pump for 18 kg drums
LAGG 18AE	Mobile grease pump for 18 kg drums
LAGG 50AE	Grease pump for 50 kg drums
LAGG 180AE	Grease pump for 180 kg drums
LAGT 180	Trolley for drums up to 200 kg



Multi-outlet drum pump GSE

Multi-outlet drum pump unit, oil or grease, for centralized single-line lubrication systems

Applications

Multi-outlet drum pump units deliver lubricants, oil or grease, to total-loss lubrication systems.

They can have up to six delivery outlets and are suited perfectly for industrial machines with several lubrication lines. They make it possible to plan simple and compact centralized lubrication systems with no need to maintain multiple lubricant containers.

They work in harsh operating conditions or in severe environments.

The GSE drum pump units come without a pump element. These pump elements, type GS100... have to be ordered separately, making it possible to have a great number of outlet combinations.

Features

- Up to 6 pump elements
- Delivers lubricant directly to several lubrication points or to large-size progressive systems
- Adaptable motor-driven pump unit that can be mounted on drums or kegs
- A minimal level control can be added to monitor the drum lubricant level
- Working pressure up to 250 bars
- The pump unit can be automated by means of an electronic control unit



Ordering details (drum pump)

Drum pump order no.*	Drum	Level control	Follower plate
VGBE GSE0-50-11	120 lbs	yes	yes
VGBE GSE0-200-11	400 lbs	yes	yes

The drum pump units are initially delivered without pump elements. The pump elements have to be ordered separately.
 *) When ordering, the Order no. has to be completed with the voltage key:
 +140: 460 V AC; +429: 115 V AC; +924: 24 V DC

Ordering details (accessories)

Pump element order no. - up to 6 (to be ordered separately)	
VGAV GS100.6.6	piston Ø6, tube connection Ø6
VGAV GS100.6.8	piston Ø6, tube connection Ø8
VGAV GS100.8.6	piston Ø8, tube connection Ø6
VGAV GS100.8.8	piston Ø8, tube connection Ø8

Ordering details (accessories for drum)

Cover order no.	Follower plate order no.	Drum
VGAV PT-130-50	VGAV GS1008-50	120 lbs
VGAV PT-120-200	VGAV GS1008-200	400 lbs

Ordering example

Multiline drum pump GSE for 50 kg drum, with level control and follower plate; power supply 230 V AC, 50 / 60 Hz; and three pump elements, piston Ø8 and tube connection Ø8.

Order no.: VGBE GSE0-50-11+428 and VGAV GS100.8.8 (x3)

See technical data on page 102.

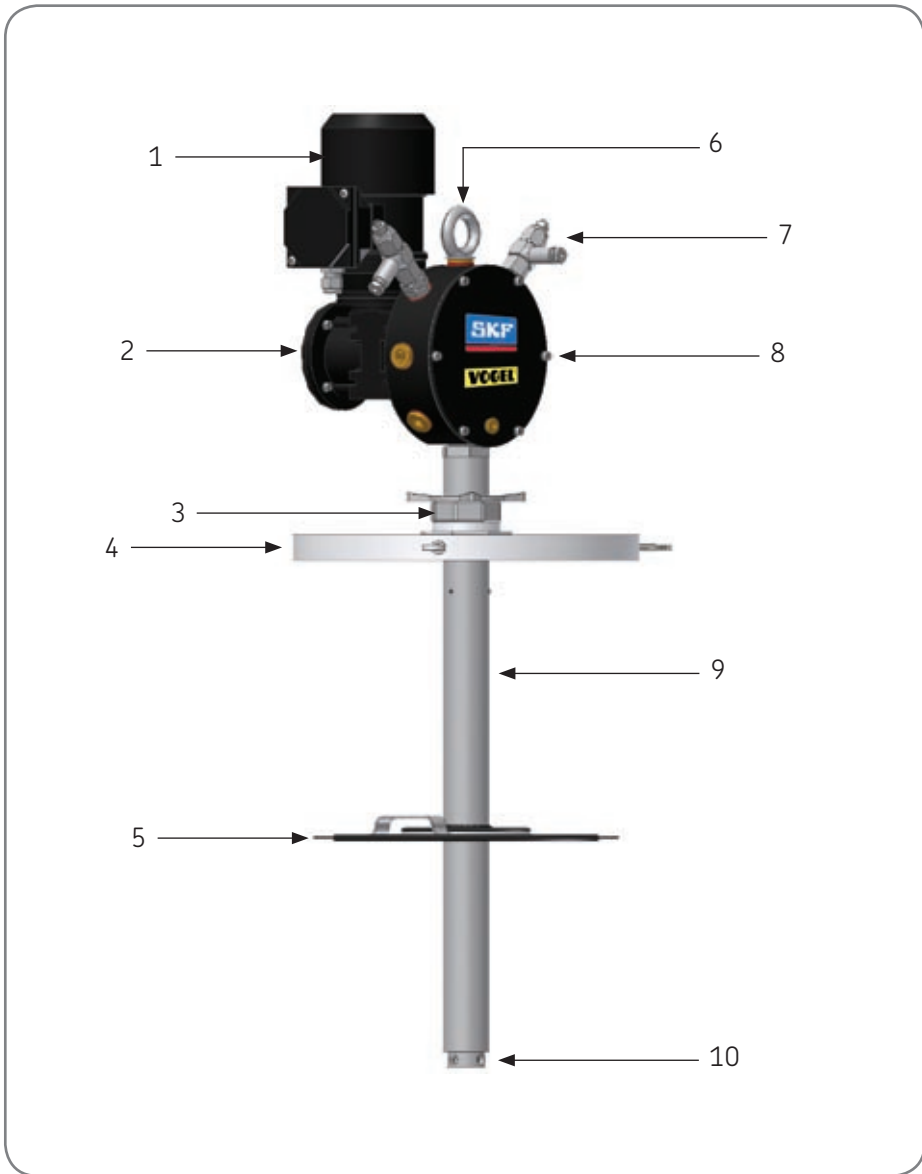

- | | |
|------------------------------------|------------------------|
| 1 Motor | 6 Lift ring |
| 2 Reducing gear | 7 Pump element |
| 3 Positioning wheel | 8 Pump housing |
| 4 Drum cover | 9 Suction pipe |
| 5 Follower plate (for grease only) | 10 Suction check valve |

Design

Flow rate adjustment

The flow rate adjustment is simple and easy for every pump element. It is performed from outside by means of a counter nut and a set screw, which adjusts the valve piston stroke.

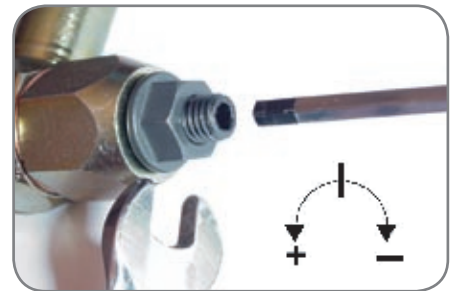

PTEX extruder pumps

Pneumatic extruder pump for drums of grease up to NLGI grade 2

Transfers lubricant to the lubrication system

The PTEX extruder pumps are pneumatically actuated pumps designed to deliver lubricant under pressure to lubrication installations.

The extruder pumps transfer the lubricant - grease from NLGI grade 000 to 2 - directly from drums of large capacity (50 kg to 200 kg). The pump then delivers the grease under pressure (up to 400 bars) according to the type of the pneumatic pump to automatic lubrication installations (progressive centralized lubrication, dual-line lubrication, chain lubrication, etc.).

Applications

The PTEX extruder pump is very reliable and simple to use. It uses one energy source (air) and can deliver greases up to NLGI grade 2 from different size containers. The PTEX extruder pump can be used in many industrial applications:

- Automotive
- Metals
- Food processing
- Mining and aggregate
- Cement works
- Assembly lines

Features

- Full consumption of the lubricant contained in the drum (less than 0.5% of lubricant remains)
- Extruder pump range for drums with different capacities (50 and 200 kg)
- Transfer of fluid greases, NLGI grades 000 to 2
- Tailor-made follower plate perfectly meets the inner diameter of the drum
- The follower plate keeps the drum tight, preventing contamination of the lubricant
- Very easy to use
- Control console with protection in order to minimize the chance of any accidental modification of the settings
- Very easy to replace the drum

When ordering a PTEX extruder pump, complete the order number with a voltage key¹⁾, indicate the inner diameter of the drum, and the material of the wiper seal.



Ordering details

Order no.	Drum capacity	Equipment	Pneumatic pump
VGPG PTEX-50-S-B	120 lbs.	standard	type B
VGPG PTEX-50-E-B	120 lbs.	electric ²⁾	type B
VGPG PTEX-200-S-A	400 lbs.	standard	type A
VGPG PTEX-200-E-A	400 lbs.	electric ²⁾	type A

1) Voltage keys: +924: 24 V DC +428: 230 V AC 50 / 60 Hz +429: 115 V AC 50 / 60 Hz

2) The electric equipment includes the general air solenoid valve and the lubricant pressure switch

The follower plate

The follower plate is delivered with the extruder pump. But it is manufactured according to the technical data of the pump in order to ensure the extruder pump reliability and optimal tightness. Therefore you have to indicate when ordering, the inner diameter (in mm) of the lubricant drum you intend to use. At the same time, you have to select the material of the wiper seal, which corresponds the best to your lubricant. We are currently offering a FPM or a nitrile wiper seal. For any further technical information, please contact SKF.

Ordering example:

PTEX-50-E-B+924, inner diameter of the drum, nitrile wiper seal

Extruder pump for a 50 kg drum (inner diameter in mm), electric option (operating voltage 24 V DC), and a wiper seal in nitrile.

See technical data on page 103.

Control console

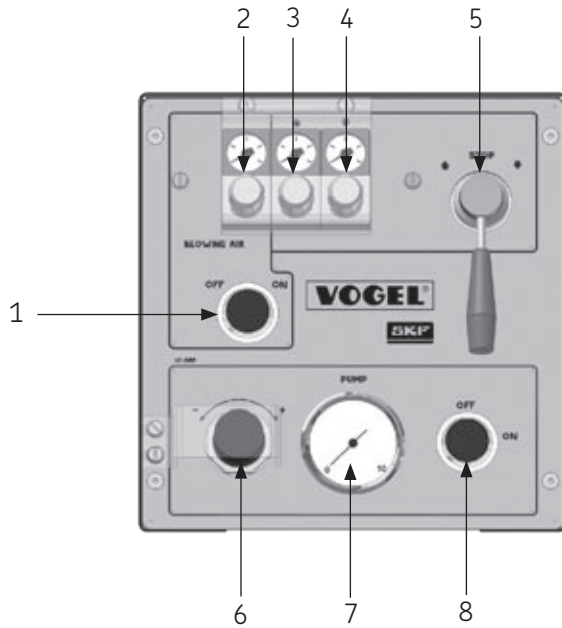

- 1 Blowing air control switch - 2 positions (On / Off)
- 2 Blowing air pressure regulator with manometer
- 3 Air pressure regulator (follower plate upward motion) with manometer
- 4 Air pressure regulator (follower plate downward motion) with manometer
- 5 Follower plate control lever - 3 positions (up, stop, down)
- 6 Air inlet pressure regulator for the pneumatic pump
- 7 Air inlet manometer for the pneumatic pump
- 8 Pump control switch - 2 positions (On / Off)

PTEX extruder pump for 25 kg drum (electric equipment)

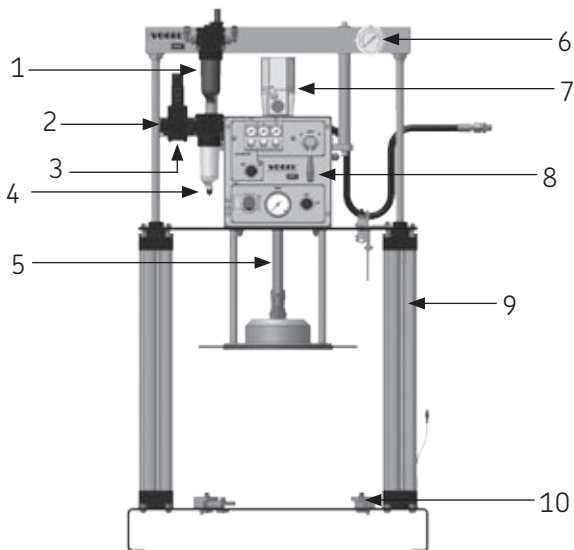

- 1 Air filter / lubricator (actuation of the pump)
- 2 Air inlet G 3/8"
- 3 Air manual control valve (or 3 / 2 solenoid valve - electric option)
- 4 Air filter
- 5 Suction pipe
- 6 Manometer (lubricant pressure)
- 7 Pneumatic pump
- 8 Control console

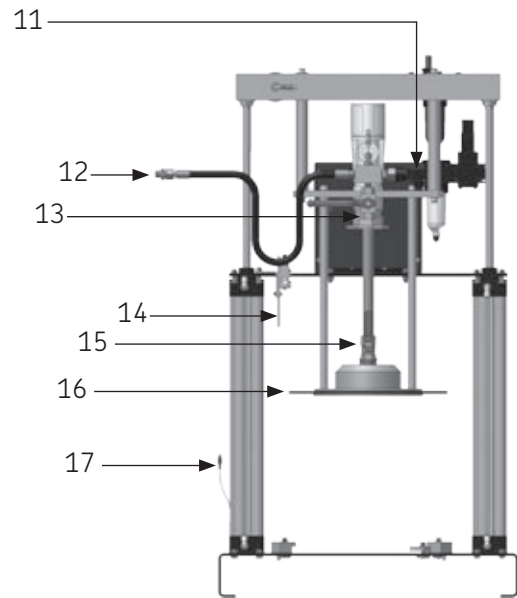

- 9 Cylinder
- 10 Flange (centering and fastening)
- 11 Pressure switch (electric option)
- 12 Lubricant outlet connection R 3/8"
- 13 Pump bleeding valve
- 14 End switch (follower plate stroke)
- 15 Drum bleeding valve
- 16 Follower plate
- 17 Position detector, type Reed switch - warning level

Lubrication Accessory Sets

Grease nozzles LAGS 8 / Grease nipples LAGN 120

The SKF LAGS 8 Grease nozzle kit provides the user with practical accessories for daily lubrication such as connectors, couplings and nozzles most widely used in the industry. To meet all of your needs for grease lubrication points, SKF has developed a grease fitting kit, LAGN 120, which contains a full range of 120 standardized conical grease fittings made of precision steel, zinc plated, hardened and blue chromated.

- Includes the most widely used accessories in the industry
- Upgrade the 1077600 grease gun with the LAGS 8 Grease nozzle kit
- Replace damaged grease fittings

Contents

Designation: LAGS 8

Straight pipe 180 mm and nozzle / Hose / Tube / Tube with nose piece and plastic transparent cover / Nipple M10 x 1-G 1/8 / Nipple M10 x 1-1/8-27 NPS / Nozzle (2x)

Contents

Designation: LAGN 120

Grease nipple

Quantity

Designation	Quantity
M6 x 1 straight	30x
M8 x 1 straight	20x
M10 x 1 straight	10x
G 1/8 straight	10x
M6 x 1 45°	5x
M8 x 1 45°	10x
M10 x 1 45°	5x
G 1/8 45°	5x
M6 x 1 90°	5x
M8 x 1 90°	10x
M10 x 1 90°	5x
G 1/8 90°	5x



Connection Systems

VOGEL quick connectors

The advantages of quick connections are obvious

- Greatly simplified installation – high cost-cutting potential
- Just one connection system for steel and plastic tubing – lower warehousing costs, simplified logistics, little danger of mixups during installation
- Triple seal – no leakage or ingress of dirt
- Easy to disconnect – saves time with modifications and repairs

The universal quick connector system from VOGEL for plastic and steel tubing

- Novel seal and locking concept meets the “zero leakage” requirements of industrial users
- Insensitive to dirt
- Easy to install
- Can be disconnected at the touch of a finger

Tools for the preparation of claw grooves on the ends of steel tubes

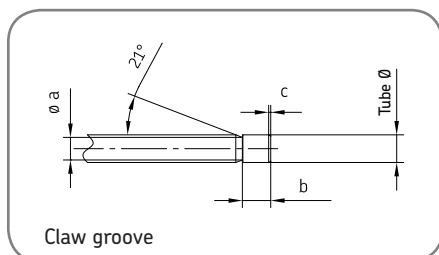
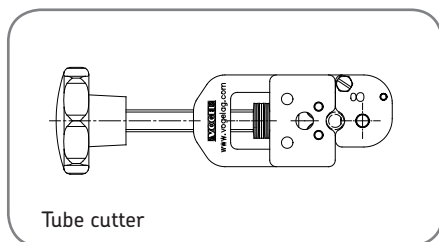

Ordering details

For tubings	Tube cutter Order no.	Claw groove dimensions		
		a ^{+0.3}	b ^{+0.2}	c
4	VGKM 169-000-336	3.1	5.0	0.3 ... 0.7
6	VGKM 169-000-337	4.9	6.2	0.4 ... 0.9
8	VGKM 169-000-338	6.9	6.2	0.5 ... 0.9

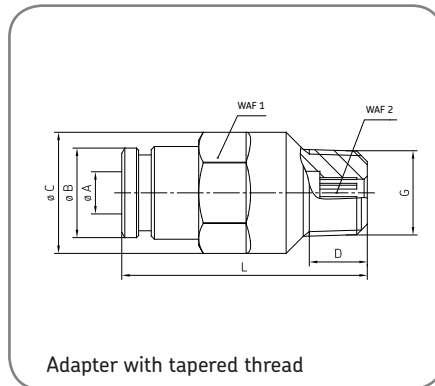
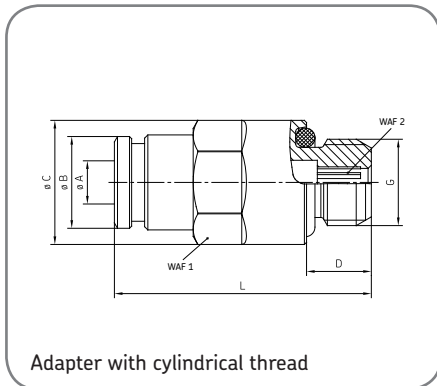

Ordering details (Adapters with cylindrical thread)

Order no.	Tube $\varnothing A$	G	D	$\varnothing B$	$\varnothing C$	L	WAF 1	WAF 2	Seal
VGKA 404-003-VS	4	M8 x 1	6	8.8	11.5	23.8	10	2.5	NBR
VGKA 404-006-VS	4	M10 x 1	6	8.8	13.5	23.8	12	2.5	NBR
VGKA 404-006-S8-VS	4	M10 x 1	6	8.8	13.5	23.8	12	2.5	FKM (FPM)
VGKA 404-040-VS	4	G 1/8	6	8.8	13.5	23.8	12	2.5	NBR
VGKA 406-158-VS	6	M8 x 1	6	11.7	13.2	30.5	12	3	NBR
VGKA 406-004-VS	6	M10 x 1	6	11.7	13.5	27	12	4	NBR
VGKA 406-004-S8-VS	6	M10 x 1	6	11.7	13.5	27	12	4	FKM (FPM)
VGKA 456-004-VS	6	G 1/8	6	11.7	13.5	27	12	4	NBR
VGKA 406-162-VS	6	M12 x 1	7	11.7	15.4	28	14	4	NBR
VGKA 406-162-S8-VS	6	M12 x 1	7	11.7	15.4	28	14	4	FKM (FPM)
VGKA 408-004-VS	8	M10 x 1	6	13.9	15.2	32.3	14	5	NBR
VGKA 408-004-S8-VS	8	M10 x 1	6	13.9	15.2	32.3	14	5	FKM (FPM)
VGKA 408-162-VS	8	M12 x 1	7	13.9	15.2	32.8	14	6	NBR
VGKA 408-162-S8-VS	8	M12 x 1	7	13.9	15.2	32.8	14	6	FKM (FPM)

Ordering details (Adapters with tapered thread)

Order no.	Tube $\varnothing A$	G	D	$\varnothing B$	$\varnothing C$	L	SW 1	SW 2
VGKA 451-004-462-VS	4	M6 tap.	5.5	8	11	25.8	10	2.5
VGKA 451-004-498-VS	4	M8 x 1 tap.	5	8.8	11.5	23.3	10	2.5
VGKA 451-004-518-VS	4	M10 x 1 tap.	5.5	8.8	11.5	22.8	10	2.5
VGKA 404-673K-V1-VS	4	1/4-28 SAE LT	5.1	8.8	11.5	26.3	10	2.5
VGKA 404-040K-V1-VS	4	1/8 NPTF	8	8.8	11.5	24.8	10	2.5
VGKA 451-006-468-VS	6	M6 tap.	5.5	11.7	13.5	30	12	2.5
VGKA 451-006-498-VS	6	M8 x 1 tap.	5.5	11.7	13.5	29.5	12	4
VGKA 451-006-518-VS	6	M10 x 1 tap.	5.5	11.7	13.5	27	12	4
VGKA 406-423W-VS	6	R 1/8 tap.	6.5	11.7	13.5	28.5	12	4

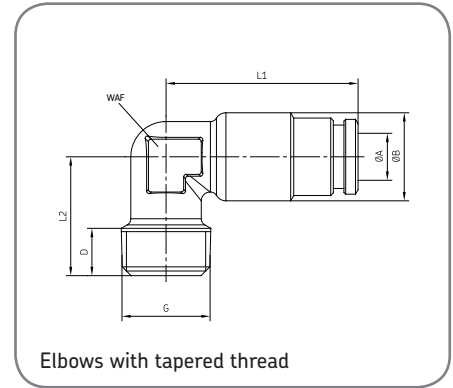
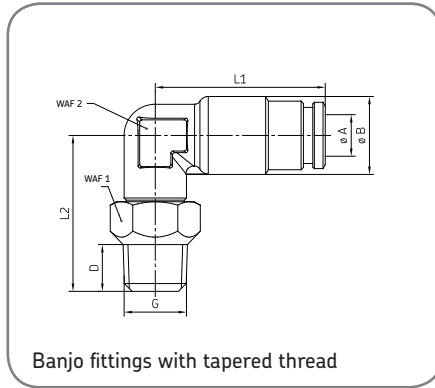
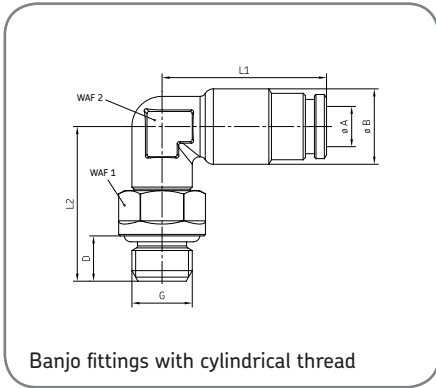

Ordering details (Banjo fittings with cylindrical thread)

Order no.	Tube ØA	G	D	ØB	L1	L2	WAF 1	WAF 2	Seal
VGKA 504-101-VS	4	M8 x 1	6	10	21.8	20.5	10	9	NBR
VGKA 504-102-VS	4	M10 x 1	6	10	21.8	20.5	12	9	NBR
VGKA 504-108-VS	4	G 1/8	6	10	21.8	20.5	12	9	NBR
VGKA 506-139-VS	6	M8 x 1	6	12.5	26	21	10	10	NBR
VGKA 506-140-VS	6	M10 x 1	6	12.5	26	21	12	10	NBR
VGKA 506-140-S8-VS	6	M10 x 1	6	12.5	26	21	10	10	FKM (FPM)
VGKA 506-108-VS	6	G 1/8	6	12.5	26	21	12	10	NBR
VGKA 506-142-VS	6	M12 x 1	7	12.5	26	23	14	10	NBR
VGKA 506-142-S8-VS	6	M12 x 1	7	12.5	26	23	14	10	FKM (FPM)
VGKA 508-142-VS	8	M12 x 1	7	14.5	28.8	23	14	12	NBR
VGKA 508-142-S8-VS	8	M12 x 1	7	14.5	28.8	23	14	12	FKM (FPM)

Ordering details (Banjo fittings with tapered thread)

Order no.	Tube ØA	G	D	ØB	L1	L2	WAF 1	WAF 2
VGKA 455-546-048-VS	4	M6 tap.	6	10	21.8	20	10	9
VGKA 455-529-048-VS	4	M8 x 1 tap.	6	10	21.8	20	10	9
VGKA 455-531-048-VS	4	M10 x 1 tap.	6	10	21.8	20	12	9
VGKA 455-529-068-VS	6	M8 x 1 tap.	6	12.5	26	20	10	10
VGKA 455-531-068-VS	6	M10 x 1 tap.	6	12.5	26	20.5	12	10

Ordering details (Elbows with tapered thread)

Order no.	Tube ØA	G	D	ØB	L1	L2	WAF
VGKA 453-004-471-VS	4	M6 tap.	6	10	21.8	14	9
VGKA 504-201-VS	4	M8 x 1 tap.	6	10	21.8	13.5	9
VGKA 504-202-VS	4	M10 x 1 tap.	6	10	21.8	13.5	9
VGKA 514-018-VS	4	R 1/8 tap.	7.5	10	21.8	15	9
VGKA 504-200K-V1-VS	4	1/4-28 SAE LT	5.1	10	21.8	15.5	9
VGKA 514-018K-V1-VS	4	1/8 NPTF	7	10	21.8	15	9
VGKA 453-006-468-VS	6	M6 tap.	6	12.5	26	15	10
VGKA 506-508-VS	6	M8 x 1 tap.	6.5	12.5	26	14	10
VGKA 506-510-VS	6	M10 x 1 tap.	6	12.5	26	14	10
VGKA 508-511-VS	6	R 1/8 tap.	8.5	14.5	26	16.5	10

Fittings and accessories

Steel and plastic tubing

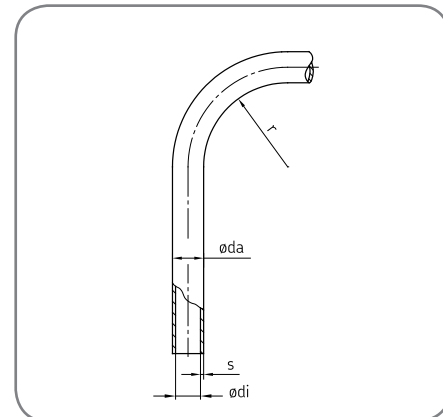

Ordering details (Steel tubing)

Order no.	Ø da ±0.05	s ±0.03	Minimum bending radius r		Design pressure [bars]	Burst pressure [bars]
			Bent with mandrel	Bent with grooved disk		
VGMD WV-R02.5x0.5 VERZI	2.5	0.5	5	-	580	1410
VGMD WV-R04x0.7 VERZI	4	0.7	8	7	500	1220
VGMD WV-R06x0.7 VERZI	6	0.7	25	12	320	850
VGMD WV-R08x0.7 VERZI	8	0.7	46	19	230	675
VGMD WV-R010x1 VERZI	10*	1	76	27	270	660

* øda ± 0.07

VERZI = 25 µm galvanization - yellow passivated. Length delivered 5 m. Stainless steel tubing on request.

Ordering details (Plastic tubing)

Order no. ¹⁾	Ø da	s	Ø di +0.15 -0.05	Smallest permissible bending radius r bent		Perm. operating pressure ³⁾ [bars]	Burst pressure [bars]
				free-hand	with fixture ²⁾		
VGMA WVN715-R02.5x0.5	2.5	0.5	1.5	25	9	66	198
VGMA WVN715-R04x0.85	4	0.85	2.3	38	14	72	216
VGMA WVN715-R06x1	6 (±0.1)	1	4	63	21	53	159
VGMA WVN715-R06x1.25	6	1.25	3.5	63	21	70	210
VGMA WVN715-R08x1.25	8	1.25	5.5	76	28	49	147
VGMA WVN715-R010x1.5	10	1.5	7	89	35	47	141
VGMA WVN715-R012x1	12 (±0.15)	1	10	110	45	24	72
VGMA WVN715-R012x1.5	12	1.5	9	110	45	38	114
VGMA WVN716-R04x0.85	4	0.85	2.3	38	14	36	108
VGMA WVN716-R06x1.25	6 (±0.1)	1.25	3.5	63	21	35	105
VGMA WVN716-R08x1.25	8	1.25	5.5	80	30	25	75

Plastic tubing:

VGMA WVN715, without plasticizer
VGMA WVN716, flexible (containing plasticizer)

Color: natural colors, black lettering. Tubing available in green, red, black or brown on request.

Tubing with other dimensions or also filled with NLGI grade 2 grease or fluid grease on request.

Important! For screwed tubing joints, only use unions with reinforcing sockets.

Material VGMA WVN715: optionally polyamide 11 (PA 11) without plasticizer or polyamide 12 (PA 12) without plasticizer to DIN 73378.

PA 12 H: polyamide 12 without plasticizer, stabilized against thermal aging.
(black tubing) PA 12 HL: polyamide 12 without plasticizer, stabilized against light-related and thermal aging.

Material VGMA WVN716: optionally polyamide 11 (PA 11) flexible or polyamide 12 (PA 12) flexible to DIN 73378.

PA 12 PH: polyamide 12 with plasticizer, stabilized against thermal aging.
(black tubing) PA 12 PHL: polyamide 12 with plasticizer, stabilized against light-related and thermal aging.

Material properties:

Very good resistance and insensitivity to oils, greases, lubricants, all fuels, chlorine-free detergents and solvents.

At room temperature good resistance to diluted mineral acids, organic acids, bases and saline solutions⁴⁾.

Inappropriate for concentrated mineral acids, concentrated acetic acid, phenols, cresols, chlorinated hydrocarbons, chlorine, acetones and ketones.

Permissible operating temperature:

approximately -60° C to +80° C (-76° to +176° F)

¹⁾ The desired length, e.g. 50 meters, has to be added to the order No. Ordering example:
VGMA WVN716-R06x1.25x50M

²⁾ These minimal radii can be produced with the help of appropriate bending devices.

The tubing has to be heated to 66° C (150° F) for this purpose - maximum duration of heating is 20 seconds.

³⁾ The operating pressures were ascertained in keeping with DIN 73378 to the formula

$$P = \frac{20 \cdot \sigma_v \cdot s \text{ (rated)}}{dm}$$

s = rated wall thickness [mm]; dm = da - s;
σ_v = reference tension N / mm² at 23° C (73° F)
At higher temperatures, the pressure drops in keeping with the pressure efficiency as per DIN 73378.

Temperature range [°C / °F]	Pressure efficiency [%]
up to 30° C / 86° F	83
up to 40° C / 104° F	72
up to 50° C / 122° F	64
up to 60° C / 140° F	57
up to 70° C / 158° F	52
up to 80° C / 176° F	47

⁴⁾ In borderline cases, consult SKF before ordering.

Fittings and accessories

High pressure hoses for self-installation
(Operating pressure: 325 bars / 130 bars)

For main lines (connection: pump-feeder) and secondary lines (connection: feeder-lubrication point)

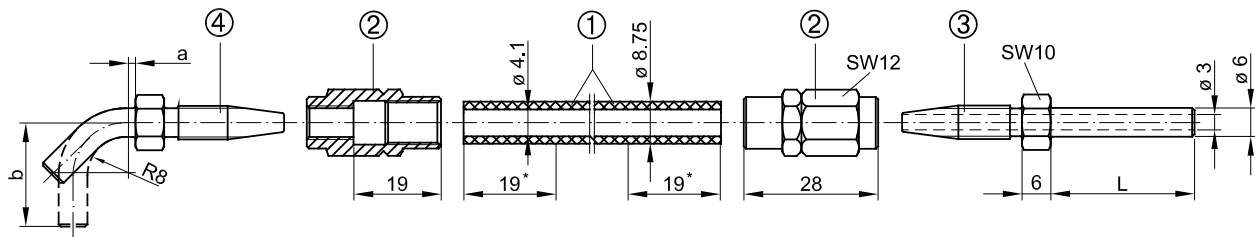

* Take length of engaged thread into account twice when determining the length of the hose.

Ordering details

Order no.	Designation	L	a	b
VGAV 982-750-091-20M	1. High press. hose, length supplied 20 m			
VGAV 982-750-091+AF2-20M	1. High press. hose, length supplied 20 m filled with NLGI grade 2 grease			
VGAV 853-540-010	2. Sleeve			
VGAV 853-370-002(-VS) ¹⁾	3. Tube stud, straight	20		
VGAV 853-380-002(-VS) ¹⁾		30		
VGAV 853-390-002(-VS) ¹⁾		66		
VGAV 853-380-003(-VS) ¹⁾	4. Tube stud, 45° angle			
VGAV 853-380-003(-VS) ¹⁾	4. Tube stud, 90° angle		2	21
VGAV 853-390-003(-VS) ¹⁾			13	47

¹⁾ Version with claw groove on ends of tubing for VOGEL quick connectors, order no. ... -VS

Electric plug-and-socket connectors

Sockets for pressure switches, level switches, flow sensors, directional control valves and filters

Electric plugs or sockets are required for the actuation of various models of hydraulic equipment used in the field of central lubrication technology and for the evaluation of switching signals.



DIN EN 175301-803/ISO 4400



M12 x 1

Ordering details

Order no.	Standard design/type	Application							
		Pressure switch	Flow sensor	Filter monitor	Lubricant level switch	Piston distributor	Oil-streak sensor	Flow monitor	Cycle switch
VGNB 179-990-034	DIN EN 175301-803/ ISO4400	•	•	•	•				
VGNB 179-990-371 straight VGNB 179-990-372 angled	4-pole type, M12 x 1	•	•	•	•	•	•	•	•
VGNB 179-990-600 straight VGNB 179-990-601 angled	4-pole type, M12 x 1 (with integrally extruded line)	•	•	•	•	•	•	•	•

Socket

To DIN EN 175301-803/ISO 4400 supplied with flat packing and fixing screw

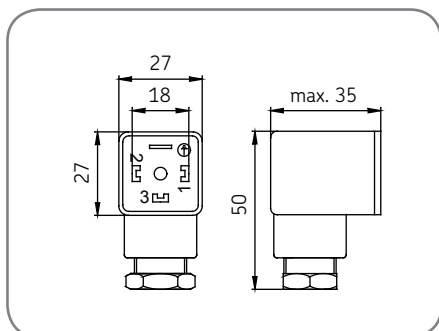

Ordering details

Order no. VGNB 179-990-034

Version	Insert rotatable 4 x 90°
Poles	3 + PE
Operating display	–
Maximum rated operating voltage	230 V AC/DC
Maximum operating current	10 A
Housing	PA, black
Approval	UL-SEV
Cable gland	PG 11 / PG 9*
Conductor cross section	max. 1.5 mm ²
Line diameter	6 to 9 mm / 4.5 to 7 mm
Type of terminal	Screws
IP enclosure DIN 40050	IP 65 (installed)
Temperature range	-40° to +80° C
Seal	Attached, NBR

* PG = heavy gauge conduit thread

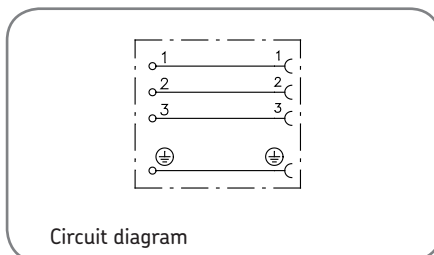

Socket M12 x 1

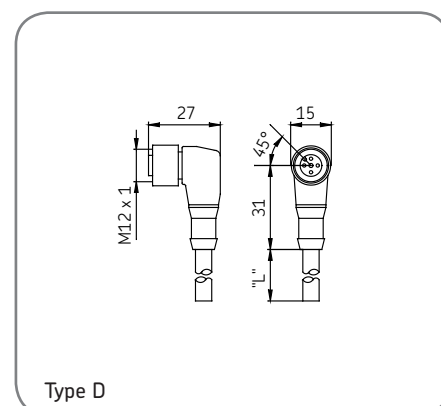
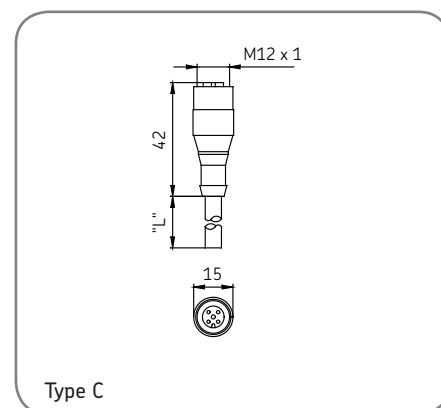
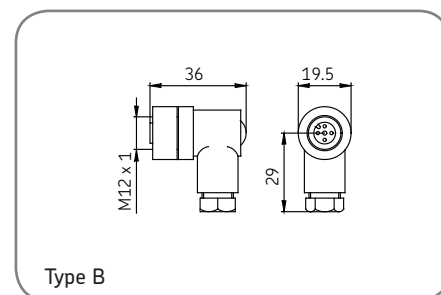
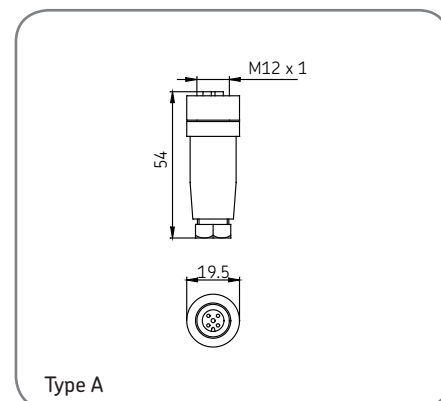

Ordering details

Order no.

VGNB 179-990-371 /
VGNB 179-990-372

VGNB 179-990-600 /
VGNB 179-990-601

Version

A / B

C / D

Poles

4

4

Maximum rated operating voltage

0 to 30 V AC/DC

10 to 30 V AC/DC

Maximum operating current

3 A

4 A

Housing

PBT-GF, black / PA, black

–

Approval

–

UL-CSA

Conductor cross section

Max. 0.75 mm²

–

Line diameter

4 to 6 mm

5 mm

Type of terminal

Screws

–

Power lead

–

5 m (4 x 0.25 mm²)
PUR / PVC

Color coding

–

cf. circuit diagram

IP enclosure DIN 40050

IP 67 (installed)

IP 68 (installed)

Temperature range

-40° to +85° C

-25° to +90° C

Seal material (O-ring)

Integrated

Integrated, FKM (FPM)

Contact assignments
(Viewing the plug side)

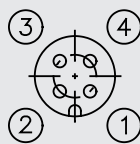
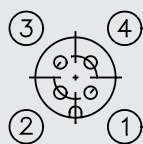

Circuit diagram

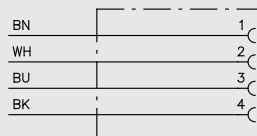
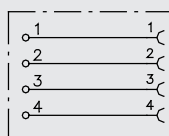

Stay-dry tank breathers

Description

SKF stay-dry tank breathers use a three-stage filtration design to ensure optimum protection by removing water vapor and solid contaminant before they enter the fluid system.

They replace the standard breather cap or vent tube on a tank or reservoir. They are easy to install using one of several adapters designed for different applications.

When the fluid in the system is lowered, or pressure changes occur, air is drawn in through openings under the breather cap. First, air passes through a fine, 2 micron solid particle filter. The air then passes through a diffuser to ensure maximum effectiveness within the silica gel chamber.

Next, water vapor is removed as the air travels through a bed of silica gel — the highest capacity absorbent available. After being dried, the air passes through a second 2 micron solid particle filter and enters the reservoir clean and dry!

Features

SKF stay-dry tank breathers protect expensive equipment, increase operation efficiency, and reduce maintenance costs by:

- Eliminating corrosion
- Extending life of hydraulic, lubrication, and process fluids
- Minimizing component wear, downtime, and repairs
- Eliminating oil oxidation, additive depletion, and freezing
- Extending oil filter life



Applications

- Hydraulic reservoirs
- Gear boxes
- Storage tanks
- Circulating oil lubrication system reservoirs

Design features

Bi-directional air flow

- Air entering is cleaned and dried. Expelled air partially regenerates the silica gel and “backflushes” the particulate filter to prolong the life of the breather.

Durable construction

- Stay-dry tank breathers are manufactured from rugged ABS plastic and impact-modified Plexiglas.

Water vapor absorbent

- Silica gel is chemically inert, non-toxic, and non-corrosive. The internal structure is composed of interconnected microscopic pores that absorb up to 40% of its weight.

Color indicator

- When maximum absorption is reached, the silica gel turns from gold to green to indicate that replacement of the breather is required.

Safety sealed

- Seals keep moisture from entering the units until they are placed in service. They are easily removed without tools or sharp instruments.

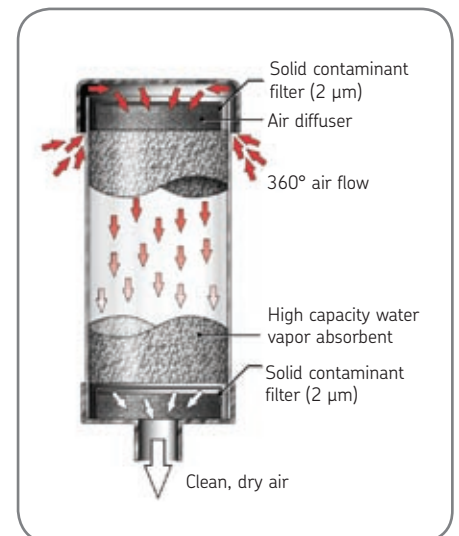

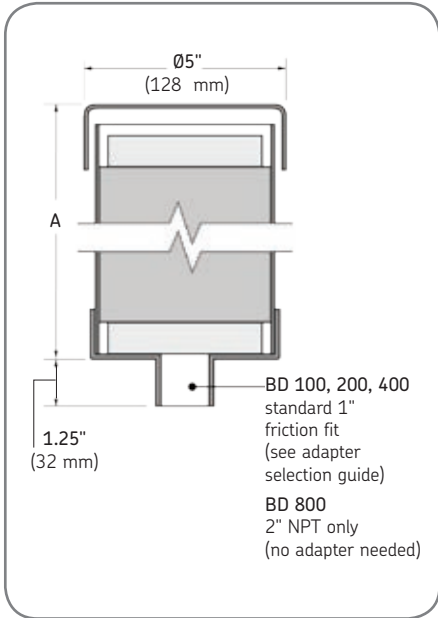

Ordering details (adapters sold separately)

Part no.	Height (A) inches (mm)	Weight lbs. (kg)	Max. H ₂ O capacity lbs. (ltr)
VGHD 9822-610-002	3.5 (90)	1.3 (0.6)	0.2 (0.1)
VGHD 9822-610-003	5 (128)	1.9 (0.9)	0.4 (0.2)
VGHD 9822-610-004	8 (205)	3.3 (1.5)	0.9 (0.5)
VGHD 9822-610-005	10 (254)	4.9 (2.2)	1.3 (0.6)

Dimensions are for general information only, all critical dimensions should be verified by requesting a certified print. Dimensions are in inches (mm) and lbs. (kg).

Adapter selection guide (adapters sold separately – Note: no adapter needed for BD 800)

Bayonet adapter
Part no. VGHD-02074251

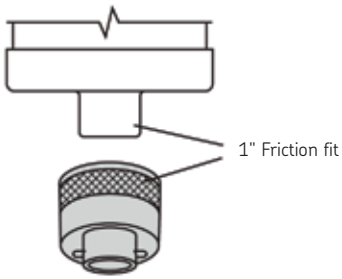

Threaded adapter
Part no. VGHD-02074248 (3/4" NPT)
Part no. VGHD-02074249 (1" NPT)

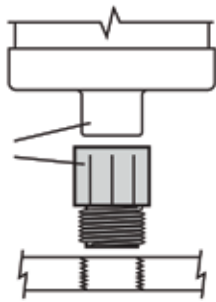

Threaded standpipe adapter
Part no. VGHD-02077124

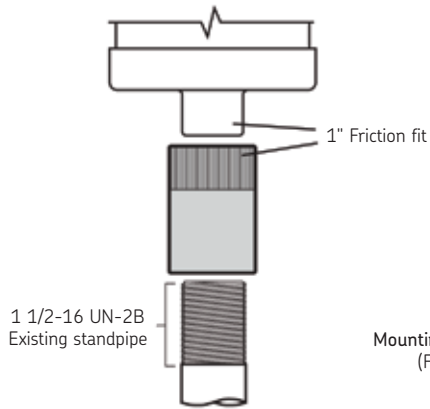

Flange adapter
Part no. VGHD-02074250 (not drilled)
Part no. VGHD-02075193 (pre-drilled)

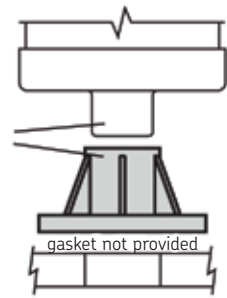

Mounting hole position for pre-drilled adapter
(Flange interface to DIN 24557/T2)

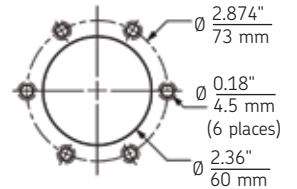

Bayonet flange kit with 3.5" steel basket
Part no. VGHD-02079076

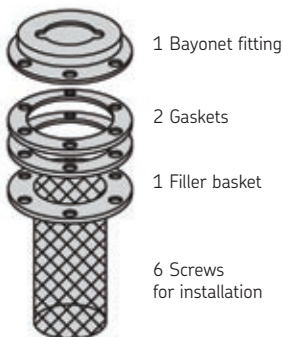

Bypass adapter
Part no. VGHD-012708016

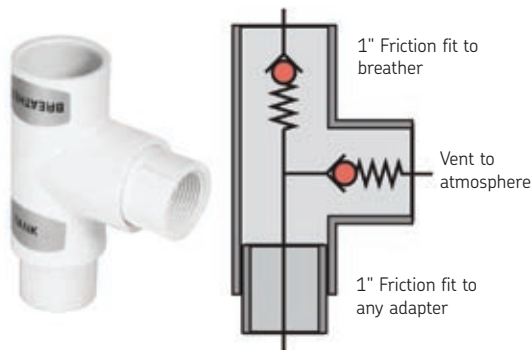

Adapter
Part no. VGHD-02081637



OilCheck Monitor TMEH 1

Detects changes in oil condition

The OilCheck measures the changes in dielectric constant of an oil. By comparing the measurements obtained from used and unused oils of the same type and brand, the SKF OilCheck is able to determine the degree of change in the condition of the oil. Dielectric change is directly related to the degradation and contamination level of the oil and will allow the user to achieve optimized intervals between oil changes and detect increased mechanical wear and loss of the oils lubricating properties. To facilitate trending, the instrument is equipped with a numerical read-out.

Important

The SKF OilCheck is not an analytical instrument. It is an instrument to detect only changes in the oil condition. The visual and numerical read-outs are purely a guide to enable trending of the comparative readings of a good oil to a used oil of the same type and brand. Do not rely solely on numerical readings.

- Shows changes in oil condition affected by such things as:
 - Water content
 - Fuel contamination
 - Metallic content
 - Oxidation
- Hand-held and user friendly
- Numerical read-out to facilitate trending



Handheld Viscometer TMVM 1

Reduce costly and time consuming laboratory analyses

The SKF viscometer TMVM 1 is a handheld rotational viscometer for quick and reliable viscosity measurements of lubrication oils and hydraulic fluids. It is suitable for both quantitative and qualitative measurements. The TMVM 1 is a first check device for carrying out on-site measurements. Regular viscosity checks help provide timely information regarding oil condition, which can have an effect on lubrication and machine performance.

- Compact light-weight design and portability of the viscometer make it an essential device for field service engineers and other field operators
- Supplied standard with a rotor suitable for a viscosity range between 30 and 1,300 MPas covering a majority of lubrication oils
- Ergonomic design makes it easy to operate with one hand
- Direct read out eliminates the need for further complex, time-consuming calculations
- Use of supplied measuring cup helps ensure reproducible measuring conditions for accurate measurements
- Excellent repeatability allowing reliable trending of oil condition
- Recalibration message displayed on the viscometer allows timely recalibration
- Alternative rotors available as accessories make viscosity measurement of other fluids possible
- Battery (4 x AA alkaline) operated, does not require a main electrical supply making it a convenient instrument for field tests
- Supplied in a sturdy carrying case for ease of portability



Portable filter cart

Maintaining clean oil in an industrial environment is a key to machine performance and reliability. The SKF portable filter cart is a solution designed to meet this need. The unit can be used to clean new oil to a low level of contamination before it is introduced into the system or to clean oil in a reservoir with a minimum number of circulation passes.

The SKF portable filter cart is designed to capture a large quantity of particulates because of the high retention capacity of the filter media and use of multiple, extended-length spin-on elements.

Features

- Availability of water removal elements with capacity of 0.45 quarts of water each
- Welded tubular steel frame for durability
- Dirt-tolerant, self-priming vane pump
- Compact design, balanced weight, and large tires for easy handling
- Color-coded gauge for warning about clogged filter elements

Applications

- Filters particles and/or water from new oil while filling a reservoir
- Recirculates and filters oil during start-up when contamination is often heaviest
- Recirculates and filters oil off-line on systems with inadequate filtering capacity
- Empties storage tanks or reservoirs
- Ideal for use in industrial plants and other demanding applications because of their efficiency, capacity, and durability



Ordering details

Stage 1 elements

003	3 micron absolute
005	6 micron absolute
010	10 micron absolute
020	20 micron absolute
010A	20 micron water removal

Stage 2 elements

003	3 micron absolute
005	6 micron absolute
010	10 micron absolute
020	20 micron absolute
010A	20 micron water removal

Example: VGHV 9823 - 020 - 010

Note: Order two-stage filter cart number VGHA 9823-440-410 for use with high viscosity oils above ISO 100. For higher viscosity oils, make sure the oil is at 100 degrees Fahrenheit before filtering. This may require the use of a drum heater.

Oil Safe®

Help reduce contamination and decrease operating costs

The Oil Safe range of products are ideal for the storage and administration of fluids and oil lubricants. Oil Safe consists of various size drums and dispensing lids, which are fully interchangeable to meet the customer's specific lubrication requirements. The lids are available in ten different colors to help in creating a color-coded system. There are five different lids (three with incorporated spout), five different size drums ranging from 1.5 to 10 liters (1.6 to 10.5 quarts). In addition, there are two different spout hose attachments and one pump that can be used with the Oil Safe utility lid.

Features

- The unique 'O' ring sealing, twist spout and lid design, keeps rain, dust and other contaminants out. This helps reduce the chance of damage to plant machinery by the use of contaminated lubricants
- Containers are heat and chemical resistant and contain UV radiation stabilizers and anti-static agents
- Products are durable and the contents are protected from environmental damage even in the harshest conditions
- Manufactured from HDPE (High Density Polyethylene) grade polymers which help prevent rust and make products suitable for indoor and outdoor use
- Lids come in ten different colors allowing different colors to be used for different oils. Color-coded labels are also available to identify the contents
- Drums all have wide-mouth openings which allows for fast, non-spill filling from bulk sources
- Drums are compact (1½, 2, 3, 5 and 10 liter), and ergonomically designed making the product easier to lift and carry
- Drums are see-through and have measuring scales so that fluids and oil lubricant levels are easy to measure and contaminants can easily be seen



Ordering details

Designation	Description	Designation	Description
LAOS 09224	Oil Safe 1.5 liter drum	LAOS 09712	Stumpy spout lid grey
LAOS 63571	Oil Safe 2 liter drum	LAOS 09729	Stumpy spout lid orange
LAOS 63595	Oil Safe 3 liter drum	LAOS 09736	Stumpy spout lid black
LAOS 63618	Oil Safe 5 liter drum	LAOS 09743	Stumpy spout lid dark green
LAOS 66251	Oil Safe 10 liter drum	LAOS 09750	Stumpy spout lid green
LAOS 09644	Oil Safe storage lid tan	LAOS 09767	Stumpy spout lid blue
LAOS 09651	Oil Safe storage lid grey	LAOS 09774	Stumpy spout lid red
LAOS 09934	Oil Safe storage lid orange	LAOS 09388	Stumpy spout lid purple
LAOS 09941	Oil Safe storage lid black	LAOS 64936	Stumpy spout lid yellow
LAOS 09958	Oil Safe storage lid dark green	LAOS 09057	Mini spout lid tan
LAOS 09965	Oil Safe storage lid green	LAOS 09064	Mini spout lid grey
LAOS 09972	Oil Safe storage lid blue	LAOS 09088	Mini spout lid orange
LAOS 09989	Oil Safe storage lid red	LAOS 09095	Mini spout lid black
LAOS 09415	Oil Safe storage lid purple	LAOS 09101	Mini spout lid dark green
LAOS 62475	Oil Safe storage lid yellow	LAOS 09118	Mini spout lid green
LAOS 09668	Utility lid tan	LAOS 09125	Mini spout lid blue
LAOS 09675	Utility lid grey	LAOS 09132	Mini spout lid red
LAOS 09866	Utility lid orange	LAOS 09194	Mini spout lid yellow
LAOS 09873	Utility lid black	LAOS 09071	Mini spout lid purple
LAOS 09880	Utility lid dark green	LAOS 06919	Contents label tan
LAOS 09897	Utility lid green	LAOS 06964	Contents label grey
LAOS 09903	Utility lid blue	LAOS 06940	Contents label orange
LAOS 09910	Utility lid red	LAOS 06995	Contents label black
LAOS 09408	Utility lid purple	LAOS 06971	Contents label dark green
LAOS 62451	Utility lid yellow	LAOS 06957	Contents label green
LAOS 09682	Stretch spout lid tan	LAOS 06988	Contents label blue
LAOS 09699	Stretch spout lid grey	LAOS 06926	Contents label red
LAOS 09798	Stretch spout lid orange	LAOS 06902	Contents label yellow
LAOS 09804	Stretch spout lid black	LAOS 06933	Contents label purple
LAOS 09811	Stretch spout lid dark green	LAOS 09422	Pump reducer nozzle
LAOS 09828	Stretch spout lid green	LAOS 67265	Stumpy spout hose extension
LAOS 09835	Stretch spout lid blue	LAOS 62499	Stretch spout hose extension
LAOS 09842	Stretch spout lid red	LAOS 62567	Pump (to fit Oil Safe utility cans)
LAOS 09392	Stretch spout lid purple	LAOS 65070	Oil Safe dealer sample pack
LAOS 62437	Stretch spout lid yellow	LAOS 09217	Oil Safe customer sample pack
LAOS 09705	Stumpy spout lid tan		



Technical data

TMBA G11D (page 82)

Designation	TMBA G11D
Pack size	50 pairs
Size	9
Color	white

LAGF series (page 82)

Designation	LAGF 18	LAGF 50
Maximum pressure	3 MPa (430 psi)	3 MPa (430 psi)
Volume / stroke	Approximately 45 cm ³ (1.5 fl oz.)	Approximately 45 cm ³ (1.5 fl oz.)
Suitable drum dimensions:		
– Inside diameter	265 – 285 mm (10.4 – 11.2 in)	350 – 385 mm (13.8 – 15.2 in)
– Maximum inside height	420 mm (16.5 in)	675 mm (26.6 in)
Weight	5 kg (11 lb)	7 kg (15 lb)

LAGG series (page 83)

Designation	LAGG 18M	LAGG 18AE	LAGG 50AE	LAGG 180AE	LAGT 180
Description	Grease pump for 18 kg drums	Mobile grease pump for 18 kg drums	Grease pump for 50 kg drums	Grease pump for 180 kg drums	Trolley for drums up to 200 kg
Pumping	Manual	Air-pressure	Air-pressure	Air-pressure	–
Maximum pressure	50 MPa (7,250 psi)	42 MPa (6,090 psi)	42 MPa (6,090 psi)	42 MPa (6,090 psi)	–
SKF Drum	18 kg (39.6 lb)	18 kg (39.6 lb)	50 kg (110 lb)	180 kg (396 lb)	180 kg (396 lb)
Inner diameter	265 – 285 mm (10.43 – 11.22 in)	265 – 285 mm (10.43 – 11.22 in)	350 – 385 mm (13.78 – 15.16 in)	550 – 590 mm (21.65 – 23.23 in)	–
Note	Stationary	Mobile	Stationary	Stationary	Mobile
Volume / stroke	1.6 cc	–	–	–	–
Volume / minimum	–	200 cc	200 cc	200 cc	–

GSE series (page 84)

		Electrical data			
		Electric motor	Three phase	Single phase	Direct current
Number of outlets	1 to 6				
Delivery rate (per stroke)					
– Piston Ø6	Adjustable from 0 to 0.08 cm ³				
– Piston Ø8	Adjustable from 0 to 0.15 cm ³				
Number of stroke	15 / min	Class	F / vented	F / vented	not vented
Pressure maximum	250 bar	Voltage	230 / 400 V	230 V	24 V DC
Outlet connection	Orientable, drilling for connectors with double tapered sleeves for tubes Ø6 or 8	Frequency	50 / 60 Hz**	50 / 60 Hz**	–
Drain plug	H 14	Power	90 W	90 W	90 W
Minimum level control	Pressure switch with connector, set at 0.5 bar	Protection	IP 55	IP 55	IP 54
Operating temperature	-10° C to +40° C	Rotation speed	1,500 rpm	1,500 rpm	1,500 rpm
Lubricant viscosity (at operating temperature)		Current 230 V	0.59 A	0.89 A	–
– Grease	Up to NLGI grade 2	Current 400 V	0.34 A	–	–
– Oil	100 to 2000 mm ² /s	Current 24 V DC	–	–	5 A
Start up	To make the start up easier fill up the pump housing via the drain plug (4)	** At 60 Hz rotation speed is multiplied by 1.2			
Material		Level control	Minimal		
– Pump element	Treated steel and brass	Switching capacity	250 V / 4A		
– Housing	Steel	Voltage maximum	250 V		
– Suction pipe	Steel	Current maximum	0.5 A		
		Type of enclosure	IP 65		
		Connector	DIN 43650		
		Cable gland	PG9		

PTEX extruder pumps (page 86)

Main data

Air consumption	900NI / min
Air inlet pressure	3 to 8 bars
Pump ratio	55 : 1
Pump delivery rate (at 6 bars)	
Pump A	0.83 kg / mn
Pump B	0.5 kg / mn
Lubricant	Greases NLGI grades 000 to 2
Operating temperature	+10° C to +50° C
Air inlet	G 3/8

Position detector, reed switch type

Maximum switching power	6 W
Switching voltage	10 to 30 V DC and AC
Maximum switching current	200 mA
Contact resistance	0.15 Ω maximum
Insulation resistance	> 100 MΩ
Withstand voltage	200 V DC
Sensitivity	2.5 mTesla minimum (25 gauss)
Repeatability	± 0.5 mm
Operating temperature	-15° C to +70° C
Degree of protection (CE I 529)	IP67
Signal indication	Orange diode (LED) which lights up when the contact is established
Connector	3-pin plug-in male connector, ØM8
Cable	PVC, Lg 0.15 m

General air solenoid valve

Type	3 / 2 NC
Connection	G 3/8
Electric connection	PG9
Delivery rate	2700 NI/mn
Operating pressure	0 to 8 bars
Operating voltage	24 V DC
Degree of protection	IP65

Lubricant pressure switch

Max. operating voltage	250 V AC
Degree of protection	IP65
Setting range	10 to 100 bars
Adm. pressure	Maximum 300 bars
Electric connection	PG9
Factory setting	None

LAGN 120 (page 88)

Designation	LAGN 120		
Maximum working pressure	40 MPa (5 800 psi)	Standard	DIN 71412
Minimum burst pressure	80 MPa (11 600 psi)	Material	Hardened steel

Quick connectors (page 89)

Maximum operating pressure	300 bars (metal tube with claw groove)
Maximum operating temperature	-40° C to +80° C
Medium	Oils, grease up to NGLI grade 2
Connection	Detachable
Material	Brass

Suitable for steel tubing with claw groove and for plastic tubing

High pressure hoses for self-installation (page 93)

Hose	
Operating pressure	325 bars
Burst pressure	800 bars
Minimum bending radius	35 mm
Materials	
Hose	Inner lining: unplasticized polyester Liner layer: braided synthetic fibers Outer cover: weatherproof polyurethane
Sleeve, tube stud:	steel, galvanized

TMEH 1 (page 98)

Designation	TMEH 1		
Suitable oil types	Mineral and synthetic oils	Battery	9V alkaline IEC 6LR61
Repeatability	Better than 5%	Battery lifetime	> 150 hours or 3 000 tests
Read-out	Green / red grading + numerical value (0 – 100)	Dimensions	250 × 95 × 32 mm (instrument) (9.8 × 3.7 × 1.3 in)

TMVM 1 (page 98)

Designation	TMVM 1
Description	Handheld viscometer
Dynamic viscosity range (MPas)	30-1300 with Rotor 3 (30 - 400.000 using optional rotors)
Motor rated voltage	4.0 VD C
Motor rated speed	62.5 rpm
Rotor supplied	R3
Repeatability	< 1 % of total range
Accuracy	± 3 % of total range with supplied rotor R3
Operating temperature	10° C to 40 ° C (50° F to 104° F)
Oil sample volume	Approx. 150 ml (5.1 fl.oz.)
Viscometer dimension (w x d x h)	175 x 88 x 170 mm (6.8 x 3.4 x 6.6 in)
Rotor dimension	D = 45.1 mm (1.7 in) h = 47 mm (1.8 in)
Rotor material	Stainless steel
Measuring cup dimension	D = 52.6 mm (2.0 in) h = 75 mm (2.9in)
Measuring cup material	Stainless steel
Battery	4 x AA (IEC type LR06) alkaline
Total weight (including case)	2.0 kg (4.4 lbs)
Packaging	Sturdy carrying case
Certificate of calibration	Yes

Portable filter cart (page 99)

Fluid compatability <i>(Note: Not allowed for use on water-based fluids)</i>	Mineral oil, including lube and fuel oil	Strainer	Stainless steel, 520 µm
Motor	1750 rpm, 3/4 HP, 110 V single phase	Hoses	Spiral-reinforced clear PVC, standard 10 ft. length 20 in. spiral wands
Electric cord	20 ft. long	Dimensions	Height 51" Width 21.5" Length 27.5"
Pump	Direct drive vane, 10 gpm, self-priming 3, 5, 10 and 20 micron, absolute-rated filters extended length spin-on, with 25 psi (1.7 bar) bypass 10 micron absolute, water removal filters extended length spin-on, approximately 0.45 quarts of water capacity, with 25 psi (1.7 bar) bypass	Weight of cart with elements	123 lbs.
Clogging indicators	Color-coded static pressure gauge	Operating range	Fluid temperature 50° F to 130° F (10° C to 54° C)
		Pressure	to 87 psi (6 bar)
		Viscosity	100 - 500 SUS

Index

Series	Description	Page	Tech Data
1077600	Grease gun	31	35
352-...-K	Metering nipples for piston distributors	74	–
391-...-K	Metering nipples for piston distributors	75	–
995-994-...	Metering nipples for piston distributors	74	–
LAGD 60	Single-point lubricator	38	48
LAGD 125	Single-point lubricator	38	48
LAGD 400	MultiPoint automatic lubricator	44	48
LAGD 1000	MultiPoint automatic lubricator	53	78
LAGE 125	Single-point lubricator	40	48
LAGE 250	Single-point lubricator	40	48
LAGF series	Grease filler pumps	82	102
LAGG 400B	Battery driven grease gun	32	35
LAGG series	Grease pumps	83	102
LAGH 400	One-hand operated grease gun	31	35
LAGM 1000E	Grease meter	34	36
LAGN 120	Grease nipple set	88	103
LAGP 400	Grease packer	30	35
LAGS 8	Grease nozzle set	88	–
LAHD series	Oil leveller	45	49
LAOS series	Oil Safe containers, lids, labels	100	–
LAPA series	Angle connectors	42	42
LAPB series	Single-point lubricator brushes	42	42
LAPC series	Single-point lubricator clamp	42	42
LAPE series	Single-point lubricator extension pipe	42	42
LAPF series	Tube connectors	42	42
LAPG series	Grease nipple	42	42
LAPM series	Y connection / manifold	42	42
LAPP series	Protective base / cover	42	42
LAPT series	Single-point lubricator flexible tube	42	42
LAPV series	Non return valves	42	42
LDT5 1	Dry lubricant for tabletop chain	21	21
LGAF 3	Anti-fretting agent	22	23
LGMT 2	All-purpose grease	11	24
LGEP 2	Extreme pressure grease	11	24
LGEM 2	Molydenum disulphide and graphite grease	14	28
LGET 2	Extreme temperature grease	13	27
LGEV 2	High viscosity molydenum and graphite grease	14	28
LGFP 2	Food applications grease	15	25
LGFB 2	Food applications, high load grease	15	25
LGGB 2	Green biodegradable grease	15	27
LGH2 2	High viscosity grease	12	27
LGHP 2	High performance grease	12	26
LGLT 2	Low temperature grease	14	26
LGMT 3	General purpose grease	11	26
LGWA 2	Wide application grease	12	27
LGWM 1	Wind mill grease	13	28
LHRP 1	Anti-corrosive agent	22	23
TMBA G11D	Disposable grease-resistant gloves	82	–
TMEH 1	OilCheck monitor	98	103
TMVM 1	Viscometer	98	104
VGAA 342-4-...	Piston distributors	74	–
VGAA 343-4-...	Piston distributors	74	–
VGAA 345-4-...	Piston distributors	74	–

(continued on next page)

Series	Description	Page	Tech Data
VGAA 351-0.	Piston distributors	74	–
VGAA 352-0.	Piston distributors	74	–
VGAA 353-0.	Piston distributors	74	–
VGAA 391-0.	Piston distributors	75	–
VGAA 392-0.	Piston distributors	75	–
VGAA 393-0.	Piston distributors	75	–
VGAA VL-1-...	Grease injectors	56	–
VGAA VL-11-85497	Grease injectors	57	–
VGAA VL-32-...	Grease injectors	57	–
VGAB VPBM-...	Progressive feeders	33	–
VGAB VSP...	Modular progressive feeders	58	–
VGAC 546-...-015-V1	Duoflex lubricant distributor	60	–
VGAV 355-0	Piston distributors	74	–
VGAV 853-...-...	Tube studs	93	–
VGAV 853-...-...-VS	Tube studs with claw grooves	93	–
VGAV 853-540-010	Sleeve	93	–
VGAV 982-750-091	High pressure hose	93	103
VGAV GS100	Drum pump elements	84	102
VGAV GS1008	Drum pump follower plates	84	102
VGAV KFA 1...	Pump elements	54	78
VGAV PT	Drum pump covers	84	102
VGBA MF	Single-circuit pumps	64	–
VGBB KFA	Electrically powered mini pump units	54	78
VGBB KFAS 1	Battery powered piston pump	55	78
VGBB MKU	Compact units for oil	72	–
VGBE GSEO	Drum pumps	84	102
VGBL 169-000-146	Piston pump (gun only)	33	36
VGBL PF-VPBM	Piston pump with block feeder	33	36
VGDA WS32-2	Level switches	67	79
VGDA WS33-2	Level switches	67	79
VGDA WS35-2	Level switches	67	79
VGDC 171-210-...	Flow monitors	76	79
VGDC GS300	Flow sensors	76	79
VGDC GS4011	Streak sensors	76	79
VGDC GS6011	Streak sensors	76	79
VGHD	Tank breathers	96	–
VGHD	Tank Breather adapters	97	–
VGHV 9823-...-...	Portable filter carts	99	104
VGKA 404-...-S8-VS	Adapters with cylindrical threads	90	–
VGKA 404-...-VS	Adapters with cylindrical threads	90	–
VGKA 404-...K-V1-VS	Adapters with tapered threads	90	–
VGKA 406-...-S8-VS	Adapters with cylindrical threads	90	–
VGKA 406-...-...-VS	Adapters with cylindrical threads	90	–
VGKA 406-...W-VS	Adapters with tapered threads	90	–
VGKA 408-...-S8-VS	Adapters with cylindrical threads	90	–
VGKA 408-...-...-VS	Adapters with cylindrical threads	90	–
VGKA 451-...-...-VS	Adapters with tapered threads	90	–
VGKA 453-...-...-VS	Elbows with tapered threads	91	–
VGKA 455-004-...-VS	Elbows with tapered threads	91	–
VGKA 455-...-...-VS	Banjo fittings with tapered threads	91	–
VGKA 456-...-VS	Adapters with cylindrical threads	90	–
VGKA 504-200-VS	Elbows with tapered threads	91	–
VGKA 504-...-VS	Banjo fittings with cylindrical threads	91	–
VGKA 504-...K-V1-VS	Elbows with tapered threads	91	–
VGKA 506-500-VS	Elbows with tapered threads	91	–
VGKA 506-...-S8-VS	Banjo fittings with cylindrical threads	91	–
VGKA 506-...-VS	Banjo fittings with cylindrical threads	91	–
VGKA 508-500-VS	Elbows with tapered threads	91	–

Series	Description	Page	Tech Data
VGKA 508-...-S8-VS	Banjo fittings with cylindrical threads	91	–
VGKA 508-...-VS	Banjo fittings with cylindrical threads	91	–
VGKA 514-...K-V1-VS	Elbows with tapered threads	91	–
VGKM 169-...-...	Tube cutters	89	–
VGKP 186-...	Accessory kit for lube point connectors	55	78
VGMA WVN715-RO	Plastic tubing	92	–
VGMA WVN716-RO	Plastic tubing	92	–
VGMD WV-RO	Steel tubing	92	–
VGNB 179-...	Electric plug-and-socket connectors	94	–
VGPA KFGS	Grease units for fans	52	–
VGPG ETP	Compact greaser for linear applications	46	49
VGPG PTEX	Drum extruder pumps	86	103
VGRV	Circulating oil fan units	62	–
VKN 550	Bearing packer	30	35

The SKF Bearing Life

Help your bearing achieve its maximum service lifetime

Every bearing has a pre-calculated service lifetime. However, research has shown that for various reasons, not every bearing achieves it. Important stages, which have a major impact on a bearing service lifetime can be recognised during the bearing's lifecycle. These stages are mounting and lubrication, alignment, re-lubrication, basic condition monitoring and dismantling.

The stages in a bearing life cycle are extremely important for achieving the maximum service life of the bearing.

By applying the right maintenance practices and using the correct tools, you can considerably extend your bearing's service life and increase plant productivity and efficiency.

Mounting and lubrication



Includes mechanical fitting tools, induction heaters and hydraulic equipment

Mounting is one of the critical stages of the bearing's lifecycle. If the bearing is not mounted properly using the correct method and tools, the bearing's service lifetime will be reduced. Lubrication is also an important step in the mounting procedure. Selecting bearing grease suitable for the application is critical to achieving optimum performance. Additionally, the quantity of grease and the lubrication method used can positively influence the service life of the bearing.

Alignment



Includes shaft and belt alignment tools and machinery shims

After the bearing has been mounted in an application, such as a motor connected to a pump, the application should be aligned. If the application is not properly aligned, the misalignment can cause the bearing to suffer additional load, friction and vibration. These can accelerate fatigue and reduce the bearing's, as well as other machine components, service life. Furthermore, increased vibration and friction can significantly increase energy consumption and the risk of premature failures.

Re-lubrication



Includes bearing greases, manual and automatic lubricators and lubrication accessories

When operating, the bearing requires correct re-lubrication practices to optimise its performance. Selecting bearing grease suitable for the application and applying the right quantities at correct intervals are essential for achieving the maximum service life of the bearing. Additionally, the re-lubrication method used can positively contribute to optimising the bearing's service life. Continuous lubrication using automatic lubricators, single or multiple-point, provides more consistent, correct and contamination-free grease supply than manual re-lubrication methods.

Basic condition monitoring



Includes temperature, noise, speed and vibration measuring instruments

During operation, it is important to regularly inspect the condition of the bearing by performing basic condition monitoring, such as temperature, vibration and noise measurements. These regular inspections will allow the detection of potential problems and help to prevent unexpected machine stops. Consequently the machine maintenance can be planned to suit the production schedule, increasing the plant's productivity and efficiency.

Cycle

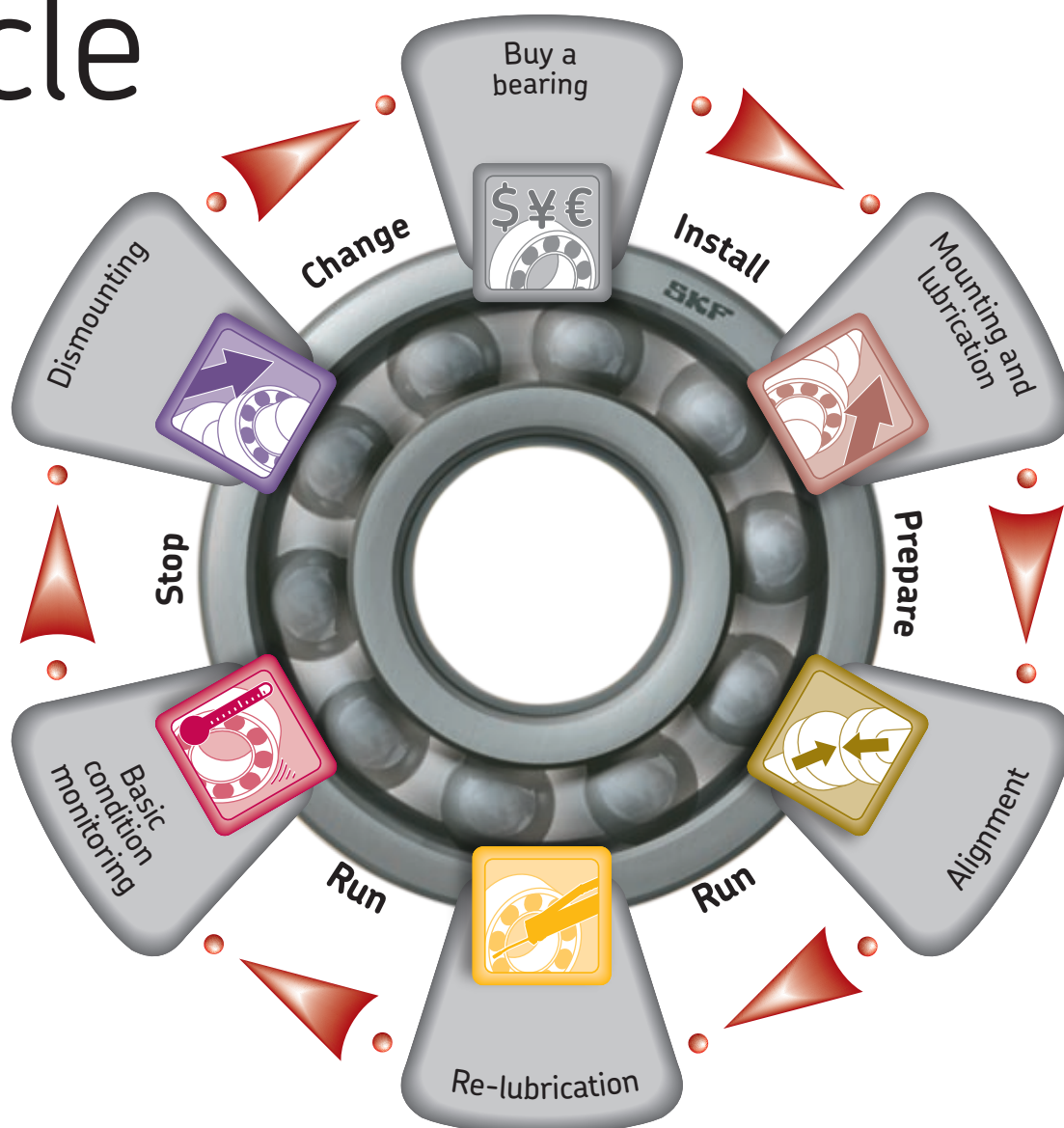

Dismounting



Includes pullers, both mechanical and hydraulic, induction heaters and hydraulic equipment

At some point, the bearing will reach the end of its service life and will have to be replaced. Although the bearing may not be used again, it is extremely important to dismount it correctly so that the service life of the replacement bearing is not compromised. Firstly, the use of proper dismounting methods tools will help prevent damage to other machine components, such as the shaft and housing, which are often re-used. Secondly, incorrect dismounting techniques can be hazardous to the operator.

SKF Maintenance and Lubrication Products catalogue

In the catalogue you will find SKF's complete range of maintenance products, which can help you get the maximum service life from your bearings. Products included in the catalogue are arranged according to the stages of the bearing life cycle: Mounting and Lubrication, Alignment, Re-lubrication, Basic Condition Monitoring and Dismounting. Publication number MP3000.

For more information about SKF maintenance products or to obtain the MP3000 catalogue, please contact your local SKF authorised distributor or SKF sales company. On the Internet, SKF can be found at www.skf.com. SKF Maintenance Products can be found at www.mapro.skf.com.

SKF Support

Reduced machinery downtime through effective bearing maintenance

Product quality is just one of the factors that determine bearing service life. Operating environment, proper installation and maintenance are also critical to bearing performance; factors that enter the picture after the bearing has been delivered to our customers.



SKF Internet sites

At www.mapro.skf.com you will find the SKF Maintenance Products catalogue online, offering a complete listing of products and technical specifications in many languages. There, you can also find a wealth of information about bearing maintenance practices as well as an extensive “frequently asked questions” section. For information on the SKF Group, history, products, divisions and services worldwide visit the SKF Group site at www.skf.com.

LubeSelect for SKF Greases

Selecting the correct lubrication for a particular bearing is a crucial step if a bearing is to live up to design expectations in its application. SKF engineers have considerable experience and knowledge of greases and oils in association with bearing operation. This knowledge has been encapsulated into a computer program called LubeSelect that can be consulted through internet connection. The program includes all SKF lubricants. LubeSelect for SKF Greases can be used **for free after registration**.

Through this service, you will access a knowledge base to help you in the selection of an appropriate lubricant for a particular application. You can select a lubricant based on application conditions or application profiles. Available from www.skf.com.

SKF DialSet 4.0 Re-lubrication calculation program

The SKF DialSet Re-lubrication Calculation program enables accurate calculation of re-lubrication intervals for lubricating bearings. The computer program determines the right time setting and dispense rates for SYSTEM 24 and SYSTEM MultiPoint.

The program is available on CD-ROM in English, French, German, Swedish, Spanish, Italian, Portuguese, Russian, Chinese and Thai languages. Reference no. MP3506. It is also available in English online as well as a downloadable version for PDA from www.mapro.skf.com.

At SKF we have put together the industry's most comprehensive program for maximising bearing service life and to help our customers reduce costly machine stoppages due to bearing failures..

For more information on the services described below, please contact please contact your local SKF authorised distributor or SKF sales company.



SKF Demonstration trucks

SKF offers demonstrations and training with mobile demonstration vehicles which tour throughout Europe, Asia and North America. The training program is tailored to the customers needs and may consist of a short theoretical explanation of the latest maintenance methods and concepts, followed by a detailed hands-on demonstration with qualified SKF personnel. For more information about these vehicles, please contact your local distributor or SKF office to schedule an appointment.



Technical literature

SKF technical literature is a must in every maintenance workshop. The SKF General Catalogue and the unique SKF Bearing Maintenance Handbook provide the answers to all mounting and dismantling questions.



Training

SKF offers training courses on all facets of bearing maintenance and machine reliability. By prior arrangement training courses can be organised at our customers own premises or at one of our well-equipped SKF Maintenance Support Centres. If you would like to know what courses are offered in your area, talk to your local SKF representative or visit www.skf.com.



© SKF, Vogel, SYSTEM 24 are registered trademarks of the SKF Group.
Safematic is a registered trademark of the John Crane Safematic Oy Company.
Oil Safe is a registered trademark of Oil Safe Systems Pty Ltd.
Safeflow is a trademark of the SKF Group.
Duoflex is a trademark of SKF USA Inc.

© SKF Group 2008
The contents of this publication are the copyright of the publisher and may not be reproduced (even extracts) unless permission is granted. Every care has been taken to ensure the accuracy of the information contained in this publication but no liability can be accepted for any loss or damage whether direct, indirect or consequential arising out of the use of the information contained herein.

www.mapro.skf.com



SKF Maintenance Products
www.mapro.skf.com / www.skf.com
Publication **MP3510E** - 2008/09